

CPT 437-34

Cyclic battery

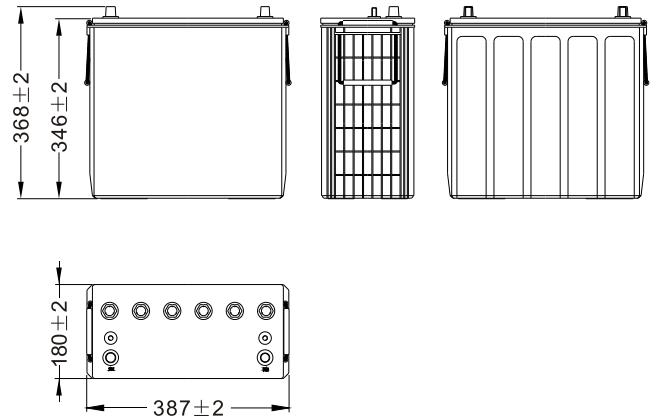

Dimensions (mm)



Physical Specification (mm)

Nominal Voltage	12V	
Nominal Capacity(20HR)	234Ah	
Nominal Capacity(5HR)	198Ah	
Dimension	Length	387 ± 2mm(15.24inches)
	Width	180 ± 2mm(7.09inches)
	Container Height	346 ± 2mm(13.62inches)
	Total Height(with Terminal)	368 ± 2mm(14.49inches)
Dry Weight	/	
Wet Weight	Approx 66.5Kg(146.5lbs)	
Acid	1.310 ± 0.015g/cm ³ (25°C)	
Standard Terminal	AM	
Hold-Down	/	
Cell plate qty	/	
Case	Black-Material	
Cover	Black-Material	
Handle	Black-Material	

Standard Terminal (mm)

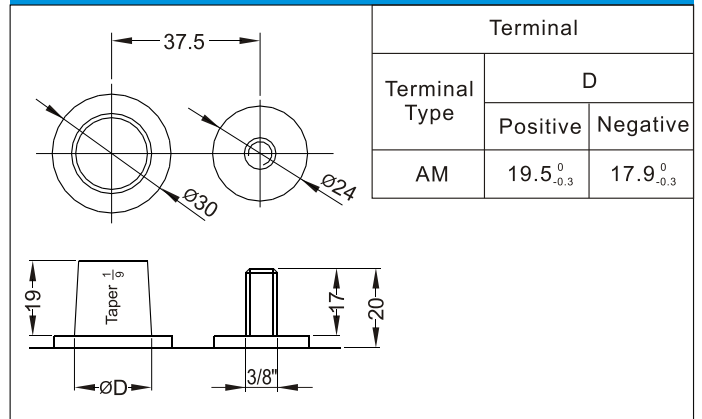

Cycle life in relation to depth of discharge

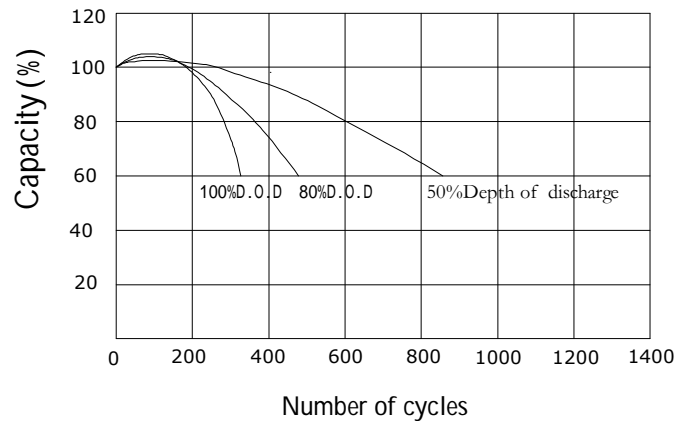

Electrical Specification

Rated Capacity	20 hour rate(11.7A)	234Ah
	5 hour rate(39.6A)	198Ah
Reserve Capacity	25Amps	518min
Reserve Capacity	75Amps	125min