

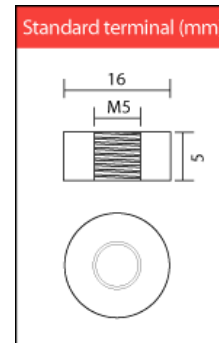

Battery for multi purpose use

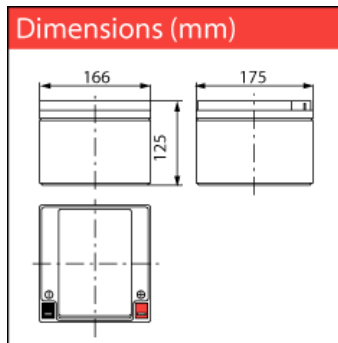

Nominal voltage	12 V	
Nominal Capacity (20HR,20 C):	26 Ah	
Internal resistance	Approx. 12 m Ω	
Maximum charging current	9.6 A	
Maximum discharge current	360 A (5 sec.)	
Operating temperature range	-20 C 50 C	
Float use/ cycle use	13,6 - 13,8V/ 14,5 – 14,9V	
Expected life (20 C)	3 – 5 years in float charge	
Standard terminal	Threaded Insert 5mm	
Housing material	ABS	
Dimensions	length	166 mm
	width	175 mm
	height	125 mm (1 mm)
Approx. Weight	9.30 kg	
Packing	1 pcs/box	

Typical applications:
 Alarm devices
 Measuring equipment
 Emergency lighting
 Medical equipment
 Telecommunication systems
 UPS systems
 Toys
 Domestic applications.

Valve Regulated Maintenance Free
 High current drain grid being resistant to corrosion by virtue of a lead-calcium alloy
 Absorbent Glassmat Technology (AGM)
 Classified as non- spillable and Non Dangerous goods by IATA, FAA, ADR, IMDG
 Can be discharged or stored in any position without leakage
 Cannot be charged while the terminal is downward

Constant Current Discharge Characteristics (A, 20°C)									
F.V/TIME	5min	10min	15min	30min	60min	3h	5h	10h	20h
9.60V	84.0	52.8	42.0	25.2	14.4	5.85	3.90	2.19	1.22
10.2V	79.8	50.2	40.3	24.2	13.8	5.76	3.84	2.17	1.21
10.8V	75.0	47.2	38.3	23.0	13.1	5.64	3.76	2.16	1.20

Constant Power Discharge Characteristics (Watt, 20°C)									
F.V/TIME	5min	10min	15min	30min	60min	3h	5h	10h	20h
9.60V	937	596	479	289	167	69.5	46.5	26.3	14.6
10.2V	891	566	460	277	160	68.4	45.8	26.1	14.5
10.8V	837	532	437	263	152	67.1	44.9	26.1	14.4

Charging characteristics

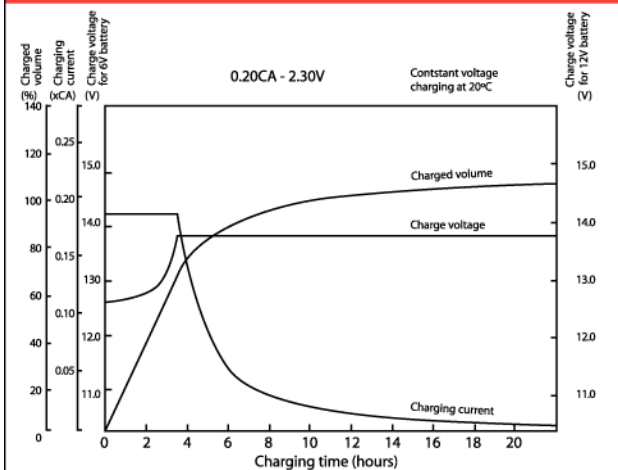

Discharge characteristics curves

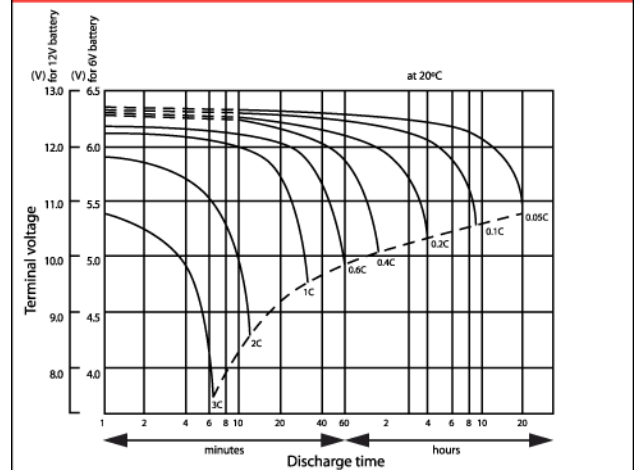

Relationship between charging voltage and temperature

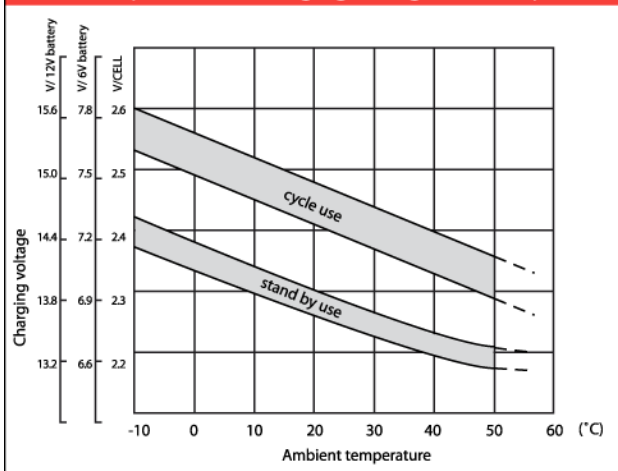

Cycle service life in relation to depth and discharge

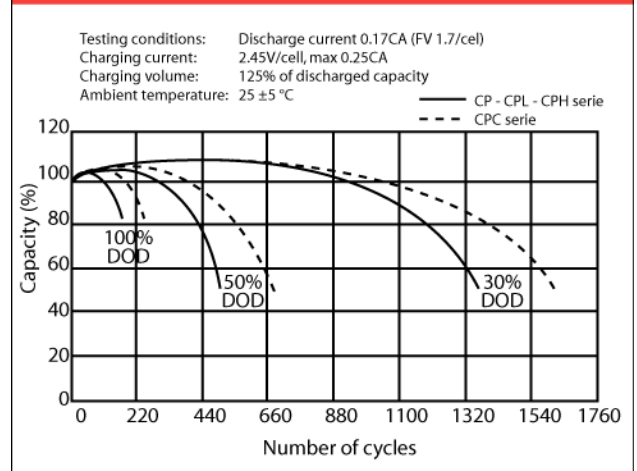

Models available

Model	Capacity (Ah)	Dimensions (mm)	Weight
CP 1.2 - 6	1.2	97 x 24 x 58	0.30 kg
CP 3.2 - 6	3.2	134 x 34 x 66	0.67 kg
CP 3.5 - 6	3.5	194 x 25 x 56	0.58 kg
CP 4 - 6	4	70 x 47 x 107	0.85 kg
CP 7 - 6	7	151 x 34 x 100	1.12 kg
CP 12 - 6	12	151 x 50 x 100	1.92 kg
CP 12 - 6L	12	151 x 50 x 100	1.92 kg
CP 0.8 - 12	0.8	96 x 25 x 62	0.36 kg
CP 1.2 - 12	1.2	97 x 43 x 58	0.58 kg
CP 2 - 12M	2	150 x 20 x 90	0.68 kg
CP 2.2 - 12	2.2	178 x 34 x 67	1.10 kg
CP 2.3 - 12C	2.3	182 x 24 x 62	0.76 kg
CP 2.9 - 12	2.9	79 x 56 x 105	1.08 kg
CP 3.2 - 12	3.2	134 x 67 x 67	1.32 kg
CP 4.5 - 12	4.5	195 x 47 x 74	1.60 kg
CP 7 - 12	7	151 x 65 x 102	2.40 kg
CP 7 - 12 L	7	151 x 65 x 102	2.40 kg
CP 12 - 12	12	151 x 98 x 101	4.10 kg
CP 18 - 12I	18	181 x 77 x 167	6.30 kg
CP 20 - 12B	20	181 x 77 x 167	6.10 kg
CP 26 - 12I	26	166 x 175 x 125	9.30 kg
CP 40 - 12I	40	197 x 165 x 170	13.10 kg
CP 65 - 12I	65	348 x 167 x 178	22.00 kg

VdS approved VRLA batteries:

The VdS-approved Cellpower batteries form a special range that has been tested and qualified by the German VdS institute. The concept behind VdS recognition; ensuring tested and certified quality in the products and services being offered in the safety and security markets, is of equally advantageous for user and supplier.

Safety and security systems are approved by the VdS and monitored in subsequent use to protect property and life and help to keep a insurance premiums lower.

Apart from the VdS approval, this range is also approved by the Dutch NCP institute, further underlining the high quality of this range.

Typical applications:

- VdS & NCP approved alarm systems
- Fire & burglar alarm systems