

isotherm

® by *ind*el marine



Marine refrigeration
& water heaters

Marine refrigerators and boxes

Isotherm by Indel Marine Cruise refrigerators are the outcome of careful research that combines technological innovation with sophisticated, yet practical design. Marine refrigerators operate under tough conditions: they must withstand violent movement, operate noiselessly, be thoroughly reliable - and perhaps most important of all - consume an absolute minimum of battery power. It is our mission to design and build high-quality and energy-efficient marine refrigeration systems exclusively for sailing yachts and motor cruisers.

Special features of the Cruise Line include:

- Fan cooled 12/24 V Danfoss compressor
- Freezer compartment
- Interior light*
- Door with a safety lock and magnetic rubber seal (offshore lock as option)
- Most models fan cooled



'ASU - Automatic Start Up' power saving control

Most small Cruise refrigerators are available with the power saving ASU - Automatic Start Up system (see pages 26-27). The control panel is separate from the refrigerator so that it can be remotely mounted up to four meters away.

Cruise refrigerators use the same compact hermetic compressor as modern domestic refrigerators. They have very low energy consumption, are nearly silent and practically indestructible.

Door handle and installation frames

The door has a magnetic rubber seal to keep it firmly closed. The handle has a safety locking device which prevents the door from being opened accidentally. The handle also has a hook to hold the door for ventilation when the refrigerator is not in use.

Cruise Line doors are hinged on the right hand side but can easily be changed to the left. Grey door panels are standard. Optional panels can be ordered in white, teak, mahogany, cherry or inox.



Refrigerators type Cruise 42, 49 and 65 are also available with white doors and s/s mounting frames.

*Not in CR42 and CR100



CRUISE 42

CR 42 is a standard size refrigerator, installed in thousands of boats. The 'back pack' compressor unit is easily removed and can be mounted in any vertical position up to 1.5 m away from the refrigerator. Mounting frame is available as an option.

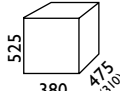
	ISOTHERM CRUISE 42	
	TYPE	CR 42
	VOLUME	42 LIT.



CRUISE 49

CR 49 follows the same standard as CR 42. Its built-in compressor gives better inside dimensions for standing and laying PET bottles. Equipped with installation frame and interior light. Available with ASU, read more on page 26-27.

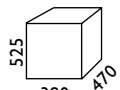
	ISOTHERM CRUISE 49	
	TYPE	CR 49 CR 49 ASU
	VOLUME	49 LIT. 49 LIT.



CRUISE 65

CR 65 features a freezer compartment with door and built-in compressor unit. Equipped with installation frame and interior light. Available with ASU, read more on page 26-27.

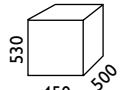
	ISOTHERM CRUISE 65	
	TYPE	CR 65 CR 65 ASU
	VOLUME	65 LIT. 65 LIT.



CRUISE 65 FREEZER

CR 65 Freezer is a 65 litres deep freezer with extra thick insulation. It has one wire shelf and a plastic basket in the bottom. It is equipped with a fan cooled compressor.

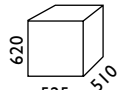
	ISOTHERM CRUISE 65 FREEZER	
	TYPE	CR 65 F
	VOLUME	65 LIT.



CRUISE 85

CR 85 with its deep door; two adjustable shelves, and corner mounted compressor; can hold a great deal of food and drinks. Supplied with interior light, installation frame as option. Available with ASU, read more on page 26-27.

	ISOTHERM CRUISE 85	
	TYPE	CR 85 CR 85 ASU
	VOLUME	85 LIT. 85 LIT.



CRUISE 100

CR 100 with air ducts and fan ventilated compressor permits circulation even in tight installations. Mounting rails available as option. Available with ASU, read more on page 26-27.

	ISOTHERM CRUISE 100	
	TYPE	CR 100 CR 100 ASU
	VOLUME	100 LIT. 100 LIT.



CRUISE 130

CR 130 is a traditional fridge with freezer compartment, three shelves and a vegetable bin. The door has three shelves. It is equipped with inner light and a fan cooled compressor. Available with ASU, read more on page 26-27.

	ISOTHERM CRUISE 130	
	TYPE	CR 130 CR 130 ASU
	VOLUME	130 LIT. 130 LIT.



CRUISE 130 DRINK

CR 130 D has instead of the freezer compartment a top section used as an extra space for drinks. It has three shelves and a vegetable bin, the door has three shelves. Bottle racks (as shown on the picture), available as option. It is equipped with inner light and a fan cooled compressor.

	ISOTHERM CRUISE 130 DRINK	
	TYPE	CR 130 D
	VOLUME	130 LIT.



CRUISE 90 FREEZER

CR 90 F has the same outside dimensions as CR 130. The extra thick insulation results in a capacity of 90 litres. It has three shelves and four separate lids. The compressor is fan cooled.

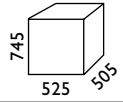
	ISOTHERM CRUISE 90 FREEZER	
	TYPE	CR 90 F
	VOLUME	90 LIT.



CRUISE 195

CR 195 is a two door fridge-freezer. A CR 130 refrigerator built on top of a 65 litres freezer. It is equipped with fan cooled compressors, a flush mounting frame, inner light and a vegetable bin. The freezer has extra thick insulation.

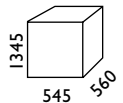
	ISOTHERM CRUISE 195	
	TYPE	CR 195
	VOLUME	130 + 65 LIT.



CRUISE 200

CR 200 is designed for easy installation under the work-surface. CR 200 is a stylish new fridge-freezer that has been developed to offer spacious onboard storage for fresh and frozen consumables. The CR 200 is divided into a 150-litre volume fridge section and a 50 litre volume freezer section. It has an AC/DC integrated electronic unit.

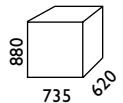
	ISOTHERM CRUISE 200	
	TYPE	CR 200
	VOLUME	150 + 50 LIT.



CRUISE 36

CR 36 is a built-in drawer fridge in a unique design. Can be installed where no other refrigerator will fit because of the lower dimensions. The compressor can be removed up to 1 m away. White door and mounting frame is standard.

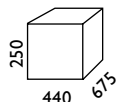
	ISOTHERM CRUISE 36	
	TYPE	CR 36
	VOLUME	36 LIT.

Isotherm Cruise INOX is an exclusive range of refrigerators with the door in stainless steel, totally flush with an integrated door latch in the front and also interior details have stainless steel trims.



ICE MAKER

This ice maker is fully automatic making the ice in a spray process. Connected directly to a pressurised water system, it quickly fills a container with fresh clear ice. Operates on 115 or 230 V. Mounting frames available as an option.

Accessory: "Water Kit", a 15 litres tank with 230 V water pump, for separate fresh water supply of the ice maker.

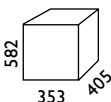
	ISOTHERM ICE MAKER	
	TYPE	IM 230 IM 115
	VOLT	220 - 240 110 - 120



CRUISE 36 INOX

CR36 Inox is a built-in drawer fridge in a unique design. Can be installed where no other refrigerator will fit because of the lower dimensions. The compressor can be removed up to 1 m away.

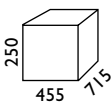
	ISOTHERM CRUISE 36 INOX	
	TYPE	CR 36 INOX
	VOLUME	36 LIT.



CRUISE 42 INOX

CR 42 Inox has a "back-pack" compressor unit which can be easily removed and mounted in any vertical position up to 1.5 m away from the refrigerator.

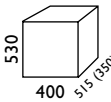
	ISOTHERM CRUISE 42 INOX	
	TYPE	CR 42 INOX
	VOLUME	42 LIT.



CRUISE 49 INOX

CR 49 Inox follows the same standard as CR 42. Its built-in compressor gives better inside dimensions for standing and laying Pet bottles. Equipped with interior light.

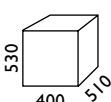
	ISOTHERM CRUISE 49 INOX	
	TYPE	CR 49 INOX
	VOLUME	49 LIT.



CRUISE 63 FREEZER INOX

CR 63 F Inox has the same outside dimensions as CR 85 Inox. CR 63 F Inox has two shelves, a bin at the bottom and a corner-mounted compressor. Evaporator piping integrated in the walls.

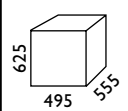
	ISOTHERM CRUISE 63 FREEZER INOX	
	TYPE	CR 63 F INOX
	VOLUME	63 LIT.



CRUISE 65 INOX

CR 65 Inox features a freezer compartments with door and built-in compressor unit. Equipped with interior light.

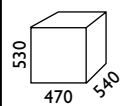
	ISOTHERM CRUISE 65 INOX	
	TYPE	CR 65 INOX
	VOLUME	65 LIT.



CRUISE 85 INOX

CR 85 Inox with its deep door, two adjustable shelves, and corner-mounted compressor; can hold a great deal of food and drinks. Supplied with interior light.

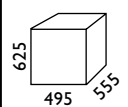
	ISOTHERM CRUISE 85 INOX	
	TYPE	CR 85 INOX
	VOLUME	85 LIT.



CRUISE 90 FREEZER INOX

CR 90 Inox freezer has the same outside dimensions as Cruise 130. The extra thick insulation results in a capacity of 90 litres. It has three shelves and four separate lids. The compressor is fan cooled.

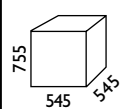
	ISOTHERM CRUISE 90 FREEZER INOX	
	TYPE	CR 90 F INOX
	VOLUME	90 LIT.



CRUISE 130 INOX

CR 130 Inox is a traditional fridge with freezer compartment, three shelves and a vegetable bin. The door has three shelves. It is equipped with inside light a fan cooled compressor.

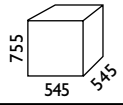
	ISOTHERM CRUISE 130 INOX	
	TYPE	CR 130 INOX
	VOLUME	130 LIT.



CRUISE 130 DRINK INOX

CR 130 D Inox has instead of the freezer compartment a top section used as extra space for drinks. It has three shelves and a vegetable bin, the door has three shelves. Bottle racks available as option. It is equipped with inner light and a fan cooled compressor.

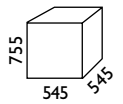
	ISOTHERM CRUISE 130 DRINK INOX	
	TYPE	CR 130 D INOX
	VOLUME	130 LIT.



CRUISE 187 INOX

CR 187 Inox is a two-door fridge-freezer. The integrated ventilation secures good ventilation even in tight installations. The interior is clean and discreet with white vegetable bins and stainless steel shelf trims. Fully automatic for 12/24-115/230V operation.

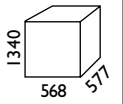
	ISOTHERM CRUISE 187 INOX	
	TYPE	CR 187 INOX
	VOLUME	142 + 45 LIT.



CRUISE 195 INOX

CR 195 Inox is a two-door fridge-freezer. A CR 130 refrigerator built on top of a 65 litres freezer. It is equipped with fan cooled compressors. The refrigerator is equipped with inner light and a vegetable bin. The freezer has extra strong insulation. It comes with flush mounting frame.

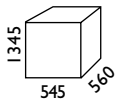
	ISOTHERM CRUISE 195 INOX	
	TYPE	CR 195 INOX
	VOLUME	130 + 65 LIT.



CRUISE 200 INOX

CR 200 Inox is designed for easy installation under the work-surface, the CR 200 Inox is a stylish new fridge-freezer that has been developed to offer spacious onboard storage for fresh and frozen consumables. Fitted with a flush mounted stainless steel door with an integrated door latch to the front of the unit. CR 200 Inox is divided into a 150-litre volume fridge section and a 50-litre volume freezer section. The interior has also been finished with stainless steel trims for an extra luxurious finish. It has an AC/DC integrated electronic unit.

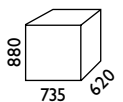
	ISOTHERM CRUISE 200 INOX	
	TYPE	CR 200 INOX
	VOLUME	150 + 50 LIT.



DRAWER 49 INOX

DR 49 Inox is a new stainless steel drawer, it's space-saving, front-opened drawer. DR 49 has a 49 litre volume and with a design based on the standard 49 litre refrigerator. The interior is designed to suit international cans and food packs with two robust drawers, intergrated adjustable bars and internal blue LED light.

	ISOTHERM DRAWER 49 INOX	
	TYPE	DR 49 INOX
	VOLUME	49 LIT.



DRAWER 55 FREEZER INOX

DR 55 Freezer Inox is a pull out drawer made in the same outside dimension as DR 65 refrigerator to allow side by side installation fridge/freezer. The extra thick insulation gives very low power consumption. DR 55 F is frost free which is unique and it do not need to be defrosted manually. An automatic de-frost cycle is integrated. The spill water controlled is led out from the freezer and evaporates on rear side. The interior got a fan evaporator to control the temperature and two robust drawers.

	ISOTHERM DRAWER 55 FREEZER INOX	
	TYPE	DR 55 F INOX
	VOLUME	55 LIT.



DRAWER 65 INOX

DR 65 Inox is a Inox stainless steel drawer, it's space-saving, front-opened drawer. DR 65 has a 65-litre volume and with a new design based on the standard 65-litre refrigerator with a pull-out drawer featuring an innovative interior design with bins and bottle racks.

	ISOTHERM DRAWER 65 INOX	
	TYPE	DR 65 INOX
	VOLUME	65 LIT.



DRAWER 105 INOX

DR 105 Inox drawer fridge gives opportunities for installations where a normal refrigerator wouldn't fit. It can be installed as the main galley fridge, as a cockpit bar or even on the fly-bridge. Available in stainless steel front panel or raw drawer front, for mounting individual wooden front panel.

	ISOTHERM DRAWER 105 INOX	
	TYPE	DR 105 INOX
	VOLUME	105 LIT.



DRAWER 190 INOX

DR 190 Inox is a refrigerator drawer box with two drawers having practical adjustable interior equipment. It has a fan cooled compressor mounted on the rear side. A three side Inox mounting frame for flush mounting is also included.

	ISOTHERM DRAWER 190 INOX	
	TYPE	DR 190 INOX
	VOLUME	190 LIT.



CRUISE 190

CR 190 is a two-door fridge-freezer. The refrigerator has a volume of 142 litres and the freezer has a volume of 45 litres. The refrigerator has inner light, three shelves and vegetable bins in the bottom.

	ISOTHERM CRUISE 190	
	TYPE	CR 190
	VOLUME	142 + 45 LIT.



CRUISE 220

CR 220 is a two-door fridge-freezer. The refrigerator has a volume of 172 litres and the freezer has a volume of 46 litres. The refrigerator has inner light, four shelves and vegetable bins in the bottom.

	ISOTHERM CRUISE 220	
	TYPE	CR 220
	VOLUME	172 + 46 LIT.



CRUISE 260

CR 260 is a two-door fridge-freezer. The refrigerator has a volume of 212 litres and the freezer has a volume of 46 litres. The refrigerator has inner light, five shelves and a vegetable bin in the bottom.

	ISOTHERM CRUISE 260	
	TYPE	CR 260
	VOLUME	212 + 46 LIT.

Hygienic interior

Isotherm Cruise refrigerators have a one-piece* inner lining of hard, polished plastic of food-quality standard with well-rounded corners for easy cleaning. This is especially important onboard a boat as, unlike the fridge at home, it is often not in use for appreciably long periods. During this time the inside becomes warm and can, if not thoroughly cleaned, become a breeding ground for bacteria. Cracks and sharp corners where a few drops of spilled milk or meat juices can hide will quickly cause the refrigerator to become an unpleasant place for food storage for all time to come!

*BI 29, 41, 53, 55, 75 & 92 have a plastic bottom inner liner with stainless steel sides.





BI 29

BI 29 a built-in refrigerator-freezer box with stainless steel inner liner and plastic bottom section. Temperature range +10° to -20°C. The lid is divided 50/50 with one section fixed. The box can be equipped with roller slides mounted to the sides, which allow the box to be used as a drawer. It must be pulled out only half way to open the lid, thanks to the lid design. It has a fan cooled compressor mounted on the inner short side, which can be repositioned up to 1.5 m away to reduce the built-in deep.

	ISOTHERM BUILT IN 29	
	TYPE	BI 29
	VOLUME	29 LIT.



BI 40

BI 40 a built-in refrigerator box with an L-shaped evaporator and rubber seal on top lid. Fan cooled side mounted compressor unit is easily repositioned up to 1.5 m away. Available with ASU, read more on page 26-27

	ISOTHERM BUILT IN 40	
	TYPE	BI 40 BI 40 ASU
	VOLUME	40 LIT. 40 LIT.



BI 41

BI 41 a built-in section with stainless steel inner liner, plastic bottom section and one wire basket. One insulation with rubber seal for the lid. Temperature range +10° to -10°C. Fan cooled compressor mounting below, easily repositioned up to 1.5 m away. Other compressor mountings as well as water cooled compressor units, SP or Magnum, available on request.

	ISOTHERM BUILT IN 41	
	TYPE	BI 41
	VOLUME	41 LIT.



BI 53

BI 53 a built-in fridge-freezer box with stainless steel inner liner, plastic bottom section and wire basket. Insulation for lids in two pieces divided 60/40 with double seal. The box has inner light. Temperature range from +10° to -20°C. Fan cooled compressor unit mounted below, which can be remotely mounted up to 1.5 m away, to reduce height by 160 mm. Other compressor mountings as well as water cooled compressor units, SP or Magnum, available on request.

	ISOTHERM BUILT IN 53	
	TYPE	BI 53
	VOLUME	53 LIT.

BI 55

BI 55 a built-in box with stainless steel inner liner, plastic bottom section and two wire basket. Interior light. Compressor unit mounted below is easily repositioned up to 1.5 m away.

	ISOTHERM BUILT IN 55	
	TYPE	BI 55
	VOLUME	55 LIT.



BI 75

BI 75 a built-in box with stainless steel inner liner, plastic bottom section and a wire basket. Insulation with rubber seal for the lid in two parts, divided 60/40. Inner light. Fan cooled compressor mounted below, easily repositioned up to 1.5 m away. Other compressor mountings as well as water cooled compressor units, SP or Magnum, available on request.

	ISOTHERM BUILT IN 75	
	TYPE	BI 75
	VOLUME	75 LIT.



BI 92

BI 92 a built-in box with stainless steel inner liner, plastic bottom section and three wire baskets. Insulation with double rubber seal for the lid in two parts, divided 50/50, inner light. Fan cooled compressor mounted below, easily repositioned up to 1.5 m away. Other compressor mountings as well as water cooled compressor units, SP or Magnum, available on request.

	ISOTHERM BUILT IN 92	
	TYPE	BI 92
	VOLUME	92 LIT.





TB 26

TB 26 with holding plate and interior light. The inside of the lid is shaped to allow two 1.5 litres PET bottles to stand upright. Built-in fan cooled compressor. Temperature range +10° to -10°C. It has recessed hand-grips.

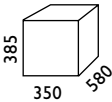
	ISOTHERM TRAVEL BOX 26	
	TYPE	TB 26
	VOLUME	26 LIT.



TB 32

TB 32 comes with a completely new injection moulded cabinet and a blow-moulded detachable lid, combining robustness with a precision finish. High-density insulation and an integrated evaporator, ensures food and drink are kept cooler for longer and an internal light makes it easier to see the contents in poor light or darkness. The TB 32 also incorporates an AC/DC converter as standard. A speed compressor selector is also provided as standard.

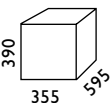
	ISOTHERM TRAVEL BOX 32	
	TYPE	TB 32
	VOLUME	32 LIT.



TB 42

TB 42 offers a roto-moulded cabinet for extra strength and a detachable two-way lid, which enables easy access to consumable where space is restricted. An integrated basket enables food items to be stored more securely. It has recessed hand-grips and mountable carrying handles. TB 42 AC/DC is a version, which offers all the benefits of the TB 42 in addition to a built-in electronic thermostat as well as an AC/DC converter. Depth can be reduced 95 mm with removed hand-grips.

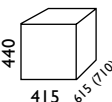
	ISOTHERM TRAVEL BOX 42	
	TYPE	TB 42 TB42 AC/DC
	VOLUME	42 LIT. 42 LIT.



TB 50

TB 50 is a travel box designed for outdoor conditions with built-in water splash protected compressor with air in-and-out-take below. Extra thick insulations means low power consumption at temperatures of +10° to -20°C deep freezer.

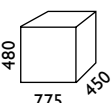
	ISOTHERM TRAVEL BOX 50	
	TYPE	TB 50 TB 50 AC/DC
	VOLUME	50 LIT. 50 LIT.



Accessories

SEH00004HA 115/230-24V converter (BD35F & BD50F)

SGF00004AA Offshore door lock CR 42-130

SBE00094AA Ventilation kit for Ice Maker 230V

SBE00108AA Ventilation kit for Ice Maker 115V

Technical specification

Type	Volume litres	Dimensions HxWxD mm	Available with ASU	Weight Kgs	Power consumption* Average/max	Danfoss Compressor Type	Freezer -6°C/21°F volume
CR 36	36	250 x 440 x 675**1)		16	0.6/2.7 A	BD35F	–
CR 42	42	525 x 380 x 475**1)		16	0.6/2.7 A	BD35F	4 (-6°C)
CR 49	49	525 x 380 x 470**	X	16	0.6/2.7 A	BD35F	4 (-6°C)
CR 65	65	530 x 450 x 500**	X	18	0.7/2.7 A	BD35F	4 (-6°C)
CR 65 F	65	620 x 525 x 510		20	1.5/5.0 A	BD35F	65 (-18°C)
CR 85	85	625 x 475 x 515**	X	20	0.8/4.0 A	BD35F	8 (-6°C)
CR 100	100	745 x 485 x 455**	X	21	1.0/4.0 A	BD35F	5 (-6°C)
CR 130	130	745 x 525 x 505**	X	23	1.2/5.0 A	BD35F	8 (-6°C)
CR 130 D	130	745 x 525 x 505**		23	1.4/5.2 A	BD35F	–
CR 90 F	90	745 x 525 x 505**		25	1.9/5.0 A	BD35F	90 (-21°C)
CR 195	130/65	1345 x 545 x 560		42	2.5/10.0 A	2 x BD35F	65 (-21°C)
CR 190	142/45	1245 x 540 x 535***		39	2.3/6.0 A	BD50F	45 (-18°C)
CR 200	150/50	880 x 735 x 620		32	2.3/6.0 A	BD50F	50 (-18°C)
CR 220	172/46	1405 x 540 x 535***		44	2.5/6.0 A	BD50F	46 (-18°C)
CR 260	212/46	1605 x 540 x 535***		51	2.5/6.0 A	BD50F	46 (-18°C)
IM	4 kgs	582 x 353 x 405		28	1.4 A 230V, 2.8 A 115V	230V/115V AC	–
CR 36 INOX	36	250 x 455 x 715 ¹⁾		18	0.6/2.7 A	BD35F	–
CR 42 INOX	42	530 x 400 x 515 ¹⁾		20	0.6/2.7 A	BD35F	4 (-6°C)
CR 49 INOX	49	530 x 400 x 510		20	0.6/2.7 A	BD35F	4 (-6°C)
CR 63 F INOX	63	625 x 495 x 555		20	1.5/5.0 A	BD35F	63 (-18°C)
CR 65 INOX	65	530 x 470 x 540		22	0.7/2.7 A	BD35F	4 (-6°C)
CR 85 INOX	85	625 x 495 x 555		24	0.8/4.0 A	BD35F	8 (-6°C)
CR 90 F INOX	90	755 x 545 x 545		29	1.9/5.0 A	BD35F	90 (-21°C)
CR 130 INOX	130	755 x 545 x 545		27	1.2/5.0 A	BD35F	8 (-6°C)
CR 130 D INOX	130	755 x 545 x 545		27	1.4/5.2 A	BD35F	–
CR 187 INOX	142/45	1340 x 568 x 577		42	2.3/6.0 A	BD50F	45 (-18°C)
CR 195 INOX	130/65	1345 x 545 x 560		42	2.5/10.0 A	2 x BD35F	65 (-21°C)
CR 200 INOX	150/50	880 x 735 x 620		36	2.3/6.0 A	BD50F	50 (-21°C)
DR 49 INOX	49	530 x 400 x 520		21	0.7/5.0 A	BD35F	–
DR 55 F INOX	55	530 x 470 x 550		24	1.5/5.0 A	BD35F	55 (-18°C)
DR 65 INOX	65	530 x 470 x 540		24	0.8/2.7 A	BD35F	–
DR 105 INOX	105	540 x 540 x 580		21	1.2/5.0 A	BD35F	–
DR 190 INOX	190	765 x 900 x 740		31	2.5/6.0 A	BD50F	–
TB 26	26	385 x 350 x 580		14	0.6/2.7 A	BD35F	–
TB 32	32	390 x 355 x 595		18	0.7/4.0 A	BD35F	–
TB 42	42	440 x 415 x 615 (710)		21	0.7/5.0 A	BD35F	–
TB 50	50	480 x 775 x 450		26	0.7/5.0 A	BD35F	50 (-20°C)
TB 50 ACDC	50	480 x 775 x 450		26	0.7/5.0 A	BD35F	–
BI 29	29	370 x 340 x 670 ¹⁾		18	0.6/4.0 A	BD35F	29 (-20°C)
BI 40	40	420 x 405 x 560 ¹⁾	X	16	0.7/2.7 A	BD35F	–
BI 41	41	625 x 340 x 500 ²⁾		19	0.7/4.0 A	BD35F	–
BI 53	53	630 x 430 x 650 ²⁾		24	1.6/5.0 A ³⁾	BD50F	53 (-20°C)
BI 55	55	660 x 360 x 650 ²⁾		22	0.7/4.0 A	BD35F	–
BI 75	75	630 x 430 x 650 ²⁾		22	0.8/5.2 A	BD35F	–
BI 92	92	615 x 485 x 805 ²⁾		28	1.0/5.2 A	BD50F	–

*) Indicates average/maximum Amp draw in operation in 12 volt with +6°C in the refrigeration space, ambient temperature +22°C. Average Amp draw will be reduced by approx. 30% for ASU models when motoring one hour a day. **) Door and door seal not included (=40mm). ***) Door and door seal not included (=55mm).

1) Depth can be reduced by 160 mm with removed compressor.

2) Height can be reduced 160 mm with removed compressor.

3) Power consumption valid for freezer.

For more technical details and dimensional drawings, please look at our web site, www.isotherm.com, or contact us. Specification changes may be done without prior notice.

Refrigeration units

Select the Isotherm System that's right for you!

On an ocean crossing or just a long weekend with friends, a successful voyage often depends on having an efficient and reliable refrigerator on board. The ideal temperature for storing fresh food such as meat, milk, fish, etc., is between +6° and +2°C. For frozen food, storage temperature should be between -14° and -16°C or even colder for long-term storage. Unstable temperature will reduce the quality and storage life of foodstuffs. It pays to choose the best fridge available to suit your needs!



Compact

The Compact thermostat-regulated refrigeration unit uses a Danfoss compressor to cool an evaporator fitted in your refrigerator or deep freezer box.



The intelligent refrigerator - charges the holding plate while the engine is running by means of the patented energy management system.



Which model should I choose?

If you have a motor cruiser, travel some distance at a time and have an efficient and well-maintained electrical system on board, choose an Isotherm Cruise refrigerator or a Classic refrigeration system that has a cold-radiating evaporator and traditional thermostat control.

If your boat is a sailing yacht and you use the engine for short periods only, we recommend you to install a fridge or refrigeration system that has Isotherm ASU control and a cold-holding plate.

Even when shore power and/or solar power is used, the Isotherm ASU system will maintain the most suitable temperature and operating parameters in either a fridge or box. In addition, when a good supply of power is available you can switch over to the "Man. temp" position and set the temperature you require inside the box manually - all the way down to well below zero if necessary. Brains and brawn again!

Compact

Cooling evaporators are available in a number of designs: the O-shaped which serves as a freezer compartment but requires slightly more space; and L- and flat-shaped which can be bent to fit the box.

These require less space and produce a slightly more even temperature distribution in the box space but have no freezer compartment. The evaporators can be fitted in any position, are fitted with 2 metre pipes, have quick-couplings and require an installation opening of only \varnothing 30 mm in the refrigerator wall.

Temperature is adjusted by a thermostat which also has an ON-OFF switch. A time-saving mounting bracket with click-on locking is available for Compact Classic as an option (included in SP). A cooling and ventilation fan is fitted to all our air-cooled models for highest efficiency.

The Compact range is available in three versions. All units are tested and comes as a complete pre-filled "do it your self" kit including everything needed.



Freezer on board!

Just a few years ago, boat owners could only dream of having a deep freezer on board. With new developments in refrigeration technology today that dream has become a reality. The ever-expanding range of fresh, semi-prepared and ready-to-eat frozen foods means better meals can be prepared with much less effort. Just imagine, hours previously spent in the galley could be used to enjoy the sailing instead.

It is important that the refrigeration unit chosen can maintain a sufficiently low and constant temperature in all conditions. If the freezer temperature is allowed to fluctuate, food quality deteriorates quickly. The ideal temperatures are -12° to -16°C for normal freezer storage and -18° to -22°C for long-term storage. Isotherm Large and Jumbo evaporators have extra large freezing surface that can be bent so that cooling energy can be radiated from all four sides.







The Isotherm Magnum model is available with a holding plate suitable for freezer and adjustable to -18°C , but it produces less stable temperature compared to the radiation type evaporator.

To achieve an even freezing effect within the box, we recommend the powerful Large or Jumbo evaporators. To determine the ideal size for your boat, divide recommended maximum volume by three and order an extra freezer thermostat kit. The size of evaporator should be chosen so that it can be shaped to fit at least two of the sides of the box.

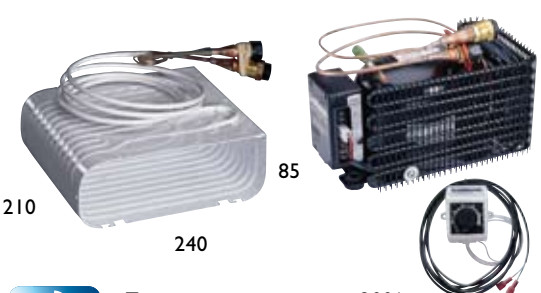
The evaporator, which is made of malleable aluminium enabling it to be shaped to comfort to the inside of the box, is available in sizes for freezers of up to 175 litres. Temperature is regulated by means of a traditional thermostat; the ASU sensing feature, which switches to full effect only when the engine is running and its ability to store cooling energy cannot be used with the large enveloping evaporators required by a high-efficiency freezer. But with a well-insulated box comparatively little energy is consumed. Information on how to build a refrigeration or deep freezer box can be found on page 28 or on our web site at www.isootherm.com.

Compact Classic

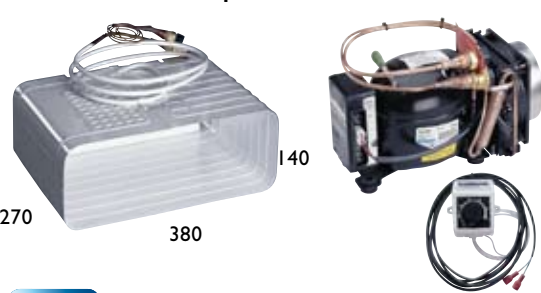
Compact Classic is a fan cooled compressor unit designed for simple installation in existing top or side-loaded refrigerator boxes. Temperature range for standard thermostats can be seen in the technical specification table on page 20.

Air cooled	
<p>Isotherm Compact Classic 200I</p>  <p>210 85 240</p> <p> Type 200I Evaporator Small-O Max box volume, fridge 125 lit. Max box volume, freezer 40 lit.</p>	<p>Isotherm Compact Classic 230I</p>  <p>230 100 320</p> <p> Type 230I Evaporator Medium-O Max box volume, fridge 150 lit. Max box volume, freezer 50 lit.</p>
<p>Isotherm Compact Classic 250I</p>  <p>270 140 380</p> <p> Type 250I Evaporator Large-O Max box volume, fridge 200 lit. Max box volume, freezer 65 lit.</p>	<p>Isotherm Compact Classic 2010</p>  <p>210 410 185</p> <p> Type 2010 Evaporator Large-L Max box volume, fridge 125 lit. Max box volume, freezer 40 lit.</p>

Technical specification table on page 20.

Air cooled

<p>Isotherm Compact Classic 2007</p>  <p>350 250 110</p> <p> Type 2007 Evaporator Small-L Max box volume, fridge 100 lit. Max box volume, freezer 30 lit.</p>	<p>Isotherm Compact Classic 2005</p>  <p>130 350</p> <p> Type 2005 Evaporator Small-Flat Max box volume, fridge 60 lit. Max box volume, freezer 20 lit.</p>
<p>Isotherm Compact Classic GE 80</p>  <p>250 350</p> <p> Type GE 80 Evaporator Flat Max box volume, fridge 80 lit. Max box volume, freezer 25 lit.</p>	<p>Isotherm Compact Classic GE 150</p>  <p>361 386</p> <p> Type GE 150 Evaporator Flat Max box volume, fridge 150 lit. Max box volume, freezer 50 lit.</p>
<p>Isotherm Compact Classic 2012</p>  <p>210 815</p> <p> Type 2012 Evaporator Flat Max box volume, fridge 170 lit. Max box volume, freezer 55 lit.</p>	<p>Isotherm Compact Classic 2016</p>  <p>190 1200</p> <p> Type 2016 Evaporator Flat Max box volume, fridge 200 lit. Max box volume, freezer 65 lit.</p>
<p>Isotherm Compact Classic 2017</p>  <p>270 1000</p> <p> Type 2017 Evaporator Flat Max box volume, fridge 260 lit. Max box volume, freezer 90 lit.</p>	<p>Isotherm Compact Classic 2013</p>  <p>300 1370</p> <p> Type 2013 Evaporator Large Flat Max box volume, fridge 400 lit. Max box volume, freezer 140 lit.</p>

Technical specification table on page 20.

SP - Self Pumping

<p>Isotherm Compact SP 205 I</p>  <p>210 85 240</p> <p> Type 205 I Evaporator Small-O Max box volume, fridge 125 lit. Max box volume, freezer 40 lit.</p>	<p>Isotherm Compact SP 235 I</p>  <p>230 100 320</p> <p> Type 235 I Evaporator Medium-O Max box volume, fridge 150 lit. Max box volume, freezer 50 lit.</p>
<p>Isotherm Compact SP 255 I</p>  <p>270 140 380</p> <p> Type 255 I Evaporator Large-O Max box volume, fridge 200 lit. Max box volume, freezer 65 lit.</p>	<p>Isotherm Compact SP 2057</p>  <p>350 250 110</p> <p> Type 2057 Evaporator Small-L Max box volume, fridge 100 lit. Max box volume, freezer 30 lit.</p>
<p>Isotherm Compact SP 2050</p>  <p>210 410 185</p> <p> Type 2050 Evaporator Large-L Max box volume, fridge 125 lit. Max box volume, freezer 40 lit.</p>	<p>Isotherm Compact SP 2055</p>  <p>130 350</p> <p> Type 2055 Evaporator Small-Flat Max box volume, fridge 60 lit. Max box volume, freezer 20 lit.</p>
<p>Isotherm Compact SP 2553</p>  <p>210 815</p> <p> Type 2553 Evaporator Flat Max box volume, fridge 170 lit. Max box volume, freezer 55 lit.</p>	<p>Isotherm Compact SP 2554</p>  <p>190 1200</p> <p> Type 2554 Evaporator Flat Max box volume, fridge 200 lit. Max box volume, freezer 65 lit.</p>

Technical specification table on page 20.

SP - Self Pumping

Isotherm Compact SP 2555



Type 2555
Evaporator Flat
Max box volume, fridge 260 lit.
Max box volume, freezer 90 lit.

Isotherm Compact SP 2556



Type 2556
Evaporator Large-Flat
Max box volume, fridge 400 lit.
Max box volume, freezer 140 lit.

Magnum

Isotherm Compact Magnum 2505

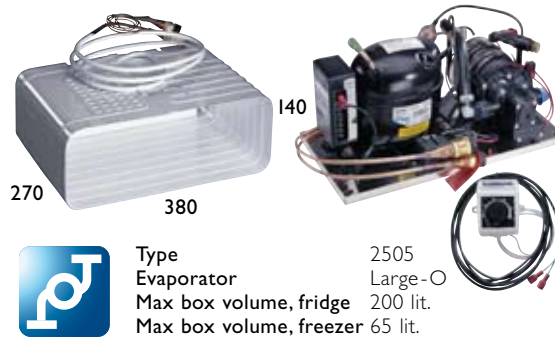

Type 2505
Evaporator Large-O
Max box volume, fridge 200 lit.
Max box volume, freezer 65 lit.

Isotherm Compact Magnum 2511



Type 2511
Evaporator Flat
Max box volume, fridge 170 lit.
Max box volume, freezer 55 lit.

Isotherm Compact Magnum 2512

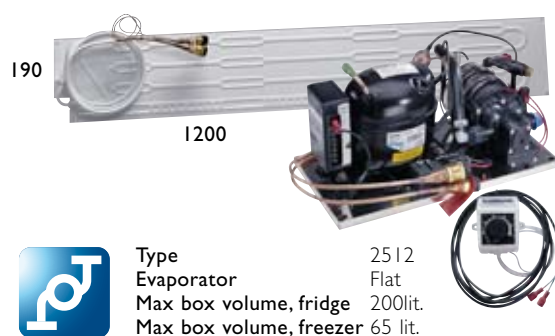

Type 2512
Evaporator Flat
Max box volume, fridge 200lit.
Max box volume, freezer 65 lit.

Isotherm Compact Magnum 2513



Type 2513
Evaporator Flat
Max box volume, fridge 260 lit.
Max box volume, freezer 90 lit.

Isotherm Compact Magnum 2507







Type 2507
Evaporator Large-Flat
Max box volume, fridge 400 lit.
Max box volume, freezer 140 lit.

Isotherm Compact Magnum 2509



Type 2509
Evaporator Jumbo-Flat
Max box volume, fridge 500 lit.
Max box volume, freezer 175 lit.

Technical specification table on page 20.

<p>Isotherm Compact Magnum 2607</p>  <p>300 1370</p>  <p>Type 2607 Evaporator Large-Flat Max box volume, fridge 425 lit. Max box volume, freezer 150 lit.</p>	<p>Isotherm Compact Magnum 2609</p>  <p>460 1500</p>  <p>Type 2609 Evaporator Jumbo-Flat Max box volume, fridge 600 Ltr Max box volume, freezer 175 Ltr</p>
------------------------------------------------------------------------------------------------------------------------------------------------------------------------------------------------------------------------------------------------------------------------------------------------------------------------------------------------------	-------------------------------------------------------------------------------------------------------------------------------------------------------------------------------------------------------------------------------------------------------------------------------------------------------------------------------------------------------

Technical specification

Type	Max volume (Fridge) litres	Dimensions evaporator A x B x C mm	Dimensions compressor L x W x H mm	Weight kgs	Power Consumption* Average A/hour/ Max A by 12 V	Danfoss Compressor Type	Temp range**
Air cooled							
GE 80	80	350 x 250	270 x 160 x 155	9	0.6/2.7 A	BD35F	Fridge
GE 150	150	386 x 361	270 x 160 x 155	9	0.7/4.0 A	BD35F	Fridge
2001	125	240 x 85 x 210	270 x 160 x 155	9	0.6/2.7 A	BD35F	Fridge
2301	150	320 x 100 x 230	270 x 160 x 155	9	0.7/4.0 A	BD35F	Fridge
2501	200	380 x 140 x 270	315 x 160 x 155	9	0.9/5.2 A	BD50F	Fridge
2005	60	350 x 130	270 x 160 x 155	9	0.6/2.7 A	BD35F	Fridge
2007	100	250 + 110 x 350	270 x 160 x 155	9	0.6/2.7 A	BD35F	Fridge
2010	125	410 + 185 x 210	270 x 160 x 155	9	0.7/2.7 A	BD35F	Fridge
2012	170	815 x 210	315 x 160 x 155	11	0.9/5.2 A	BD50F	Combi
2016	200	1200 x 190	315 x 160 x 155	12	1.0/6.2 A	BD50F	Combi
2017	260	1000 x 270	315 x 160 x 155	12	1.0/6.2 A	BD50F	Combi
2013	400	1370 x 300	315 x 160 x 155	12	1.2/6.2 A	BD50F	Combi
SP							
2051	125	240 x 85 x 210	210 x 135 x 155	11	0.6/2.5 A	BD35F	Fridge
2351	150	320x 100 x 230	210 x 135 x 155	11	0.7/3.8 A	BD35F	Fridge
2551	200	380 x 140 x 270	210 x 135 x 155	13	0.8/5.0 A	BD50F	Fridge
2055	60	350 x 130	210 x 135 x 155	10	0.55/2.5 A	BD35F	Fridge
2057	100	250 + 110 x 350	210 x 135 x 155	10	0.6/2.5 A	BD35F	Fridge
2050	125	410 + 185 x 210	210 x 135 x 155	11	0.65/3.8 A	BD35F	Fridge
2553	170	815 x 210	210 x 135 x 155	13	0.85/5.0 A	BD50F	Combi
2554	200	1200 x 190	210 x 135 x 155	13	0.95/6.0 A	BD50F	Combi
2555	260	1000 x 270	210 x 135 x 155	13	1.0/6.0 A	BD50F	Combi
2556	400	1370 x 300	210 x 135 x 155	14	1.15/6.0 A	BD50F	Combi
Magnum							
2505	200	380 x 140 x 270	440 x 220 x 175	15	1.1/6.1 A	BD50F	Combi
2511	170	815 x 210	440 x 220 x 175	15	1.0/4.1 A	BD50F	Combi
2512	200	1200 x 190	440 x 220 x 175	15	1.1/6.1 A	BD50F	Combi
2513	260	1000 x 270	440 x 220 x 175	15	1.15/6.1 A	BD50F	Combi
2507	400	1370 x 300	440 x 220 x 175	16	1.4/6.1 A	BD50F	Combi
2509	500	1500 x 460	525 x 225 x 175	22	3.5/10.0 A	BD50Fx2	Combi
2607	425	1370 x 300	440 x 220 x 175	16	1.5/10.5 A	BD80F	Combi
2609	600	1500 x 460	440 x 220 x 175	17	2.1/10.5 A	BD80F	Combi

* Indicates average/maximum Amp draw in operation (12 volt) with +6°C in the refrigeration space, which is half the recommended max box volume, with an ambient/water temperature of +22°C and medium sized insulation. (PU thickness 1 mm/lit.) For a comparison between air and water cooled models, read FAQ on page 30.

** Fridge temperatures: down to +2°C. Combi thermostat temperature range: Fridge temperature and down to -14°C. Divide recommended max volume by two for a combi unit. Deep freeze temperature range: -17°C to -22°C. Use optional freezer or double thermostat for colder temperatures on the fridge models. For more technical information, look at our web site: www.isotherm.com. Reduce recommended box volume with 10-20% for tropical conditions. Specification changes may be made without prior notice.



Freezer compartment door



Skin fitting valve kit for SP



Double thermostat with switch



A practical click-on mounting bracket suitable for horizontal or vertical mounting is included in SP models.



Fasten the bracket and lift the compressor into place.



'Click!' The compressor locks onto the bracket without adjustments or tools.



Air circulation fan
SBE0007ICA

Accessories

SEH00004HA	115/230 - 24 volt converter (BD35F & BD50F)
SBE00004AA	Hose vent kit
SGE00002AA	Click on bracket*
SGC00005AA	Freezer compartment door Small-O
SGC00004AA	Freezer compartment door Medium-O
SGC00003AA	Freezer compartment door Large-O
SEA00011DA	Freezer thermostat kit 0 to -22°C
SEA00004DA	Double thermostat kit 10 to -22°C
SBD00031AA	Extension pipes 1 m incl. couplings
SBD00032AA	Extension pipes 2 m incl. couplings
SBD00033AA	Extension pipes 3 m incl. couplings
SBE00006AA	SP spare zinc anode
SBE00008AA	Magnum zinc anode
SFD00008AA	SP skin fitting valve kit
SBE00071CA	Air circulation fan

* Included in SP, option for air cooled units and does not fit Magnum models.

Isotherm ASU

Isotherm ASU systems are designed for installations in existing cool boxes and mainly for use in sailing yachts where battery power is at a premium. The ASU system dramatically reduces power consumption while supplying refrigeration in abundance. It senses when surplus power is available from the engine alternator and speeds up the compressor to rapidly freeze the holding plate. When surplus power is no longer available it reduces its energy-use accordingly. The stainless-steel holding plate can be fitted at any suitable angle high up in the box before being connected to the compressor unit by the three meter long six mm diameter flexible copper piping fitted with quick-couplings. The compressor unit is small enough to be fitted in a stowage within connecting distance from the holding plate. Extremely quiet when running, it can even be fitted under a bunk if needed. After connecting the leads to the battery, the pre-filled system is ready to go. More details about its operation can be found on page 27.

Isotherm ASU	
<p>Isotherm ASU 320I</p>  <p> Type Evaporator Max box volume 320I Small holding plate 125 lit.</p>	<p>Isotherm ASU 370I</p>  <p> Type Evaporator Max box volume 370I Medium holding plate 200 lit.</p>
<p>Isotherm ASU 325I SP</p>  <p> Type Evaporator Max box volume 325I Small holding plate 125 lit.</p>	<p>Isotherm ASU 375I SP</p>  <p> Type Evaporator Max box volume 375I Medium holding plate 200 lit.</p>
<p>Isotherm ASU 420I Magnum</p>  <p> Type Evaporator Max box volume 420I Medium holding plate 200 lit.</p>	<p>Isotherm ASU 470I Magnum</p>  <p> Type Evaporator Max box volume 470I Large holding plate 240 lit.</p>

Technical specification table on page 23.

Isotherm ASU 490I Magnum



Type 490I
Evaporator XX-Large holding plate
Max box volume 500 lit.

Isotherm ASU 580I Magnum



Type 580I
Evaporator X-Large holding plate
Max box volume 325 lit.

Isotherm ASU 530I Magnum



Type 530I
Evaporator Large holding plate
Max box volume 260 lit.

Accessories

SEH00003HA	115/230-24 volt converter (BD35F)
SEH00004HA	115/230 volt converter (BD35F & BD50F)
SBE00004AA	Hose vent kit
SEC00003DA	Box inner light kit
SBE00006AA	Spare zinc anode SP
SFD00008AA	Skin fitting valve kit (see page 21)
SGC00006AA	Ice cube tray
SBE00008AA	Spare zinc anodes Magnum
SBD00031AA	Extension pipes 1 m incl. couplings
SBD00032AA	Extension pipes 2 m incl. couplings
SBD00033AA	Extension pipes 3 m incl. couplings

A practical click-on mounting bracket suitable for horizontal or vertical mounting is included in ASU Air and SP models.

Fasten the bracket and lift the compressor into place.

'Click!' The compressor locks onto the bracket without adjustments or tools.



The ASU system is controlled from a special control panel. Switch to 'Normal/Auto' and this unique system operates in fully-automatic mode maintaining the correct temperature at an absolute minimum battery load. If battery power management is not vital - as when connected to shore-power or running on solar panels - the 'Man/Temp' mode can be selected and temperature adjusted manually by turning the dial on the panel.

There is also an ice cube tray SGC00006AA in s/s available as an option, to be placed on the holding plate, where special plastic bags for making ice cubes can be placed.

Isotherm ASU is delivered as a complete do-it-yourself kit. Everything is pre-filled and ready-to-go. The cold-holding plate and compressor are connected together by quick-fit couplings that can be connected and disconnected at will. This allows us to thoroughly test all units during production ensuring the highest possible quality. Cables and connectors are of telephone-type.

Technical specification

Type	Max volume (fridge) litres	Dimensions Holding Plate L x W x H mm	Dimensions Compressor L x W x H mm	Weight kgs	Power Consumption* Average/max (12V)	Danfoss Compressor Type	Temp range**
320I	125	300 x 210 x 60	270 x 160 x 155	14	0.4/5.0 A	BD35F	Fridge
370I	200	355 x 280 x 60	315 x 160 x 155	16	0.65/6.2 A	BD50F	Fridge
325I	125	300 x 210 x 60	210 x 135 x 155	15	0.35/4.8 A	BD35F	Fridge
375I	200	355 x 280 x 60	210 x 135 x 155	17	0.55/6.0 A	BD50F	Fridge
420I	200	355 x 280 x 60	440 x 220 x 175	19	0.9/7.1 A	BD50F	Fridge
470I	240	355 x 280 x 90	440 x 220 x 175	23	1.0/7.1 A	BD50F	Fridge
490I	500	530 x 325 x 117	440 x 220 x 175	32	1.6/10.5 A	BD80F	Fridge
530I	260	355 x 280 x 90	525 x 225 x 175	27	1.3/10.3 A	BD50Fx2	Fridge
580I	325	400 x 320 x 90	525 x 225 x 175	30	1.4/10.3 A	BD50Fx2	Fridge

* Indicates average/maximum Amp draw in operation (12 volt) with +6°C in the refrigeration space, which is half the recommended max box volume, with an ambient/water temperature of 22°C and medium sized box insulation, (PU 1 mm/lit.). For a comparison between air and water cooled models, read FAQ on page 30.

** Fridge temperatures; down to +2°C. Amp draw calculated using only battery power and engine stopped. Running engine for 1/2 - 1 1/2 hours daily reduces current consumption by 50 - 90 % on ASU models. For more technical details and full dimension drawings please look at our web site, www.isootherm.com or contact us. Reduce recommended box volume with 10-20% for tropical conditions. Specification changes may be made without prior notice.

Cooling - to remove heat from the food

A refrigerator does not produce cold but removes heat! An effective means of getting rid this heat is critical for the refrigerator's performance and energy consumption. Isotherm refrigeration systems use either air or sea water to remove heat.



Air-cooling

Air-cooling is traditional way of removing heat with a condenser where air is blown through by a fan. It is important that the compressor compartment is ventilated, so that cold air enters from below and hot air is allowed to escape above. The lower in the boat the compressor is installed the more "help" it gets from the outside water.



Self-pumping sea water cooled

- Sea water cooling for even higher efficiency.
- Lower power consumption.
- Silent - no fan or pumps.
- Heat removed by water means cooler inside the boat.
- No extra holes in hull required and no protrusions.
- Simple to fit. Replaces the through-hull fitting for galley sink.

The Isotherm SP system is a technique that is cooled directly by the surrounding water. This means that refrigeration efficiency is completely independent of the air temperature inside the boat. Even on the hottest day of summer – just when a refrigerator is needed most – the water-cooled Isotherm SP operates consistently at an extremely high level of efficiency impervious to hot ambient temperatures. Without fans or pumps to remove the heat generated by the refrigeration compressor, the SP system consumes much less battery power and is remarkably quiet. Although heat always rises if left to laws of nature, the Isotherm SP unit uses the natural movements of the hull to draw heat down and out through a special fitting in the galley sink drain hose. As this hose is not restricted by pumps or non-return valves, the flow inside is completely free. Each movement of the water surrounding the boat produces a similar quantity of water level inside the hose resulting in the pumping

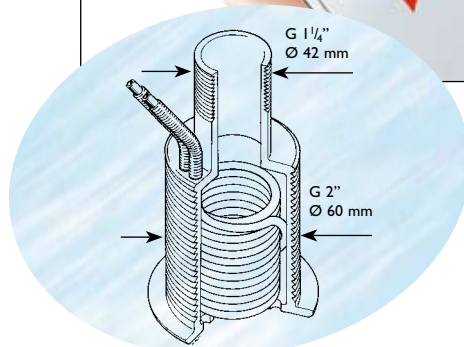
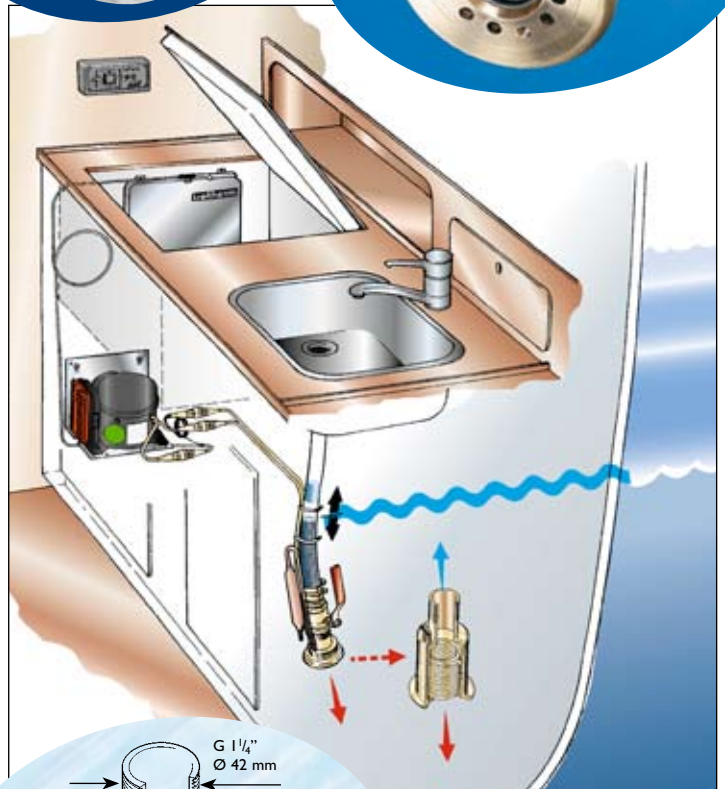

of a similar quantity of water in and out through the hull fitting. By designing a special hull fitting containing a non restricting, full-flow spiral heat exchanger for cooling the heated refrigeration agent, an extremely efficient cooling system is created. As the hull fitting is always situated some distance from the boat's centre of gravity, even the smallest movement of the hull or mast of sailing boat is sufficient to create a pumping action. This movement by which warm water is continuously pumped out and cold water in also prevents fouling. The through-hull fitting is made of saltwater resistant brass and the full-flow coil heat exchanger is of copper nickel alloy. A zinc anode comes with the kit. The 1.5 metre pipe connecting it to the compressor and the 3 metre pipe from the holding plate are both prefilled and fitted with quick-fit connectors. For more information see FAQ on page 30.



Isotherm Magnum – Electric pump sea water cooled

Isotherm Magnum is designed especially for vessels where refrigeration requirements are exceptionally large or for extended sailing in tropical waters. Isotherm Magnum uses the surrounding water, always appreciably cooler than the air inside the boat, to increase cooling efficiency. All Magnum models are fitted with integral sea water pumps for circulating the cooling water through the cooling section of the refrigerator compressor. The pump is quiet, self-priming, withstands being run dry and is self-aerating. The highly efficient heat exchanger is manufactured in a corrosion-resistant copper-nickel alloy and fitted with a zinc anode. Sea water systems are unmatched in efficiency and offer increased cooling capacity.

Isotherm Magnum Twin

The Magnum Twin model is the largest and most modern refrigeration unit in the range, using twice the compressor power as the smaller Magnums. By connecting two Danfoss compressors together even the largest refrigerators (up to 500 litres) or freezer (up to 175 litres) will work to capacity. For trouble-free operation over long periods, the lubrication systems of both compressors are connected by means of an oil cooler ensures continuous operation at full capacity even in tropical conditions. An internal light kit is available (Part no. SEC00003DA). For detailed information concerning operation and functions for shore power, solar panels, etc., read the ASU information on pages 26 – 27.

Cold facts

Only quality and purpose-designed refrigeration equipment can achieve the high level of reliability required.

Leaders in the field of marine refrigeration, Isotherm by Indel Marine has developed the innovative patented ASU, Automatic Start Up system that dramatically improves the efficiency of yacht refrigeration systems.



Isotherm leads development in on board cooling!

Isotherm ASU was the first system which automatically regulated the speed of the compressor by registering the level of refrigeration required and the electrical power available at any given time, a technique which looks likely to become one of the future energy-saving systems even for household refrigerators. It has the ability to determine when a surplus of power is available. The heart in the Isotherm system is the all new Danfoss compressor, for which we have developed a new generation of the patented ASU "Automatic Start Up" electronic control system.

Together with an Isotherm holding plate they are an unbeatable combination. The new smaller Danfoss compressors are even more power efficient, still almost silent when running, they work in a mixture of oil and refrigerant this helps contribute to the extremely quiet running and long life expected, a hermetically sealed compressor.

The Isotherm speciality, is in that all the compressors are running on a three-phase electric system, as all other high efficiency electric motors. The three-phase current is created in a small microprocessor: In this "computer" we have also been able to programme in a number of functions that check and control many of the units systems thus achieving the lowest possible power consumption. And it is well tested, been on the market since years.

The same compressor is used for both 12 V and 24 V systems, and the electronic unit is able to protect itself from an accidental reversal of voltage polarity, however the most advanced part of the system is still the ASU "Automatic Start Up"!

Third generation refrigeration compressors with refined ASU system.

The new Danfoss compressor is not only smaller, it is also considerably lighter and more power efficient. In a system without ASU, the power savings could be as much as 20% compared with older compressor types. With ASU and other refinements, power consumption could be reduced by as much as 50% compared to previous models. It is so quiet that we now include a speed control feature for the fan as this created even more noise than the compressor. The new ASU system now runs both the compressor and fan as slowly as possible when running only on battery power.

How much power is needed?

This is the most frequently asked question of all. For our complete Isotherm refrigerators and boxes, we can give exact power consumption figures as we know their size and quality of insulation.

It is more difficult to quote a figure for our refrigeration systems as we do not know the exact size of the box, or even more important, the quality and thickness of the insulation material used. The power consumption figures given for a particular volume are therefore calculated for an insulation material of medium quality and thickness. The average power consumption is given in Ampere/hour:

ASU compared to Classic refrigerator

Isotherm ASU charges the holding plate while the engine is running.

The patented ASU system has now been available for more than 15 years and has been installed on tens of thousands of boats worldwide. The ASU system always starts the compressor when the engine is running and the power is "free" to chill the holding plate completely. The energy stored in the holding plate will keep the refrigerator cool for many hours. When the engine is stopped, the compressor will not restart until the energy stored in the plate is all but consumed. Only then will the compressor start to run for short periods to maintain the required temperature in the box. The ASU system always uses the stored energy before automatically starting the compressor when the engine is running. With its unique principle of operation – the patented ASU "Automatic Start Up" system – Isotherm ASU has the advantage over traditional refrigerators.

ASU - Automatic Start Up

This unique system is designed to run the compressor primarily when the engine is running and plenty of power is available, making it preferable to have as large a compressor as possible to chill the holding plate rapidly. By taking advantage of the surplus energy generated by the alternator when the engine is running, the ASU feature does not reduce the engine's effectiveness. The Isotherm ASU system increases the speed of the compressor up to 75% when the engine is running, to freeze the holding plate rapidly and effectively. This can only be done by a three-phase compressor with full-range speed control. The "intelligent" microprocessor is useful even when running only off the battery. If, for example, a crate of warm beer is placed in the refrigerator, or its door is inadvertently left open, the ASU function will speed up the compressor just enough to keep its contents cool. For larger refrigeration requirements and greater energy sources, Isotherm Twin ASU is a good option. The Isotherm Twin system expands the refrigeration range from compressors running at low speed to two compressors running at high speed. With both brain and brawn, Isotherm automation turns on full power only when it's required – and available!

Isotherm ASU - perfect for solar panels and shore power

The ASU function senses when only a small amount of current is being produced by either a solar panel or battery charger and registers the difference between this trickle charge and the shorter but much higher charging level produced by engine's alternator. In this situation the holding plate is charged slowly and at a rate consistent with the energy being produced by the power source.

Isotherm by Indel Marine Refrigerators

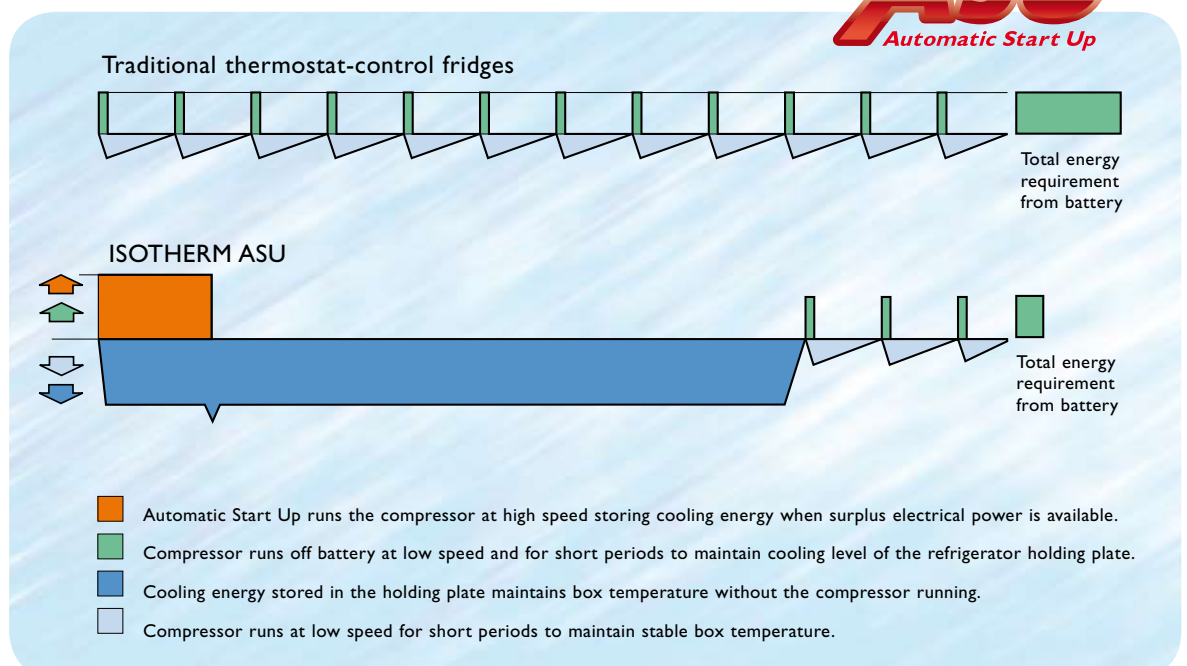

Build a cold box in your boat. It is not difficult at all!

Most boats are different but they do tend to have one thing in common and that is that they have very few right angles or regular shaped compartments. There are usually very few boats that can take a ready-made refrigerator or freezer - you just have to make it yourself! We can supply a flat-pack set of ready-cut insulated panels to help you build a customised box. The panels are covered on both sides with 2.5 mm plastic laminate of foodstuff quality and have 46 mm thick closed cell foam insulation in between. They are easy to cut and glue together using a polyurethane sealant or mould resistant silicone resulting in joints that are leak-proof but not totally inflexible. The kit consists of three insulation panels measuring 978x478x50 mm. Cover strips for the edges of the lid are included together with simple instructions.

A top-opening box is usually preferable. The cold air is not leaking out when the box is opened to the same degree as for a front opened fridge. A box can also be designed to fit the shape of the interior and the hull.

Select a suitable place on board where the box can be built. It is to prefer that the box is built in connection to the galley. Don't build a bigger box than really necessary, it is better economy to have a smaller well filled up than a bigger half full box. The box contents should be easy accessible from above. The lid is normally a storage yard. The lid opening should be not larger than give access to both hands, when loading or taking out goods. It is a great help if the area for the box can be completely made free for moulding and building. Avoid building the box close to warm engine room or heater compartment. If that cannot be avoided, extra insulation must be added. Also have in mind that the connection pipe to the compressor is 2.5 m on evaporators and 3 m long on holding plates. Try to create as many right angles as possible. Make the bottom as big as possible. The bottom shall be made in a size allowing the sides standing on the bottom panel. The bottom must be carefully fastened in the interior, the box filled with goods must withstand the forces during sailing in rough seas. Very often, additional supports and brackets must be manufactured. Normally it is to prefer that

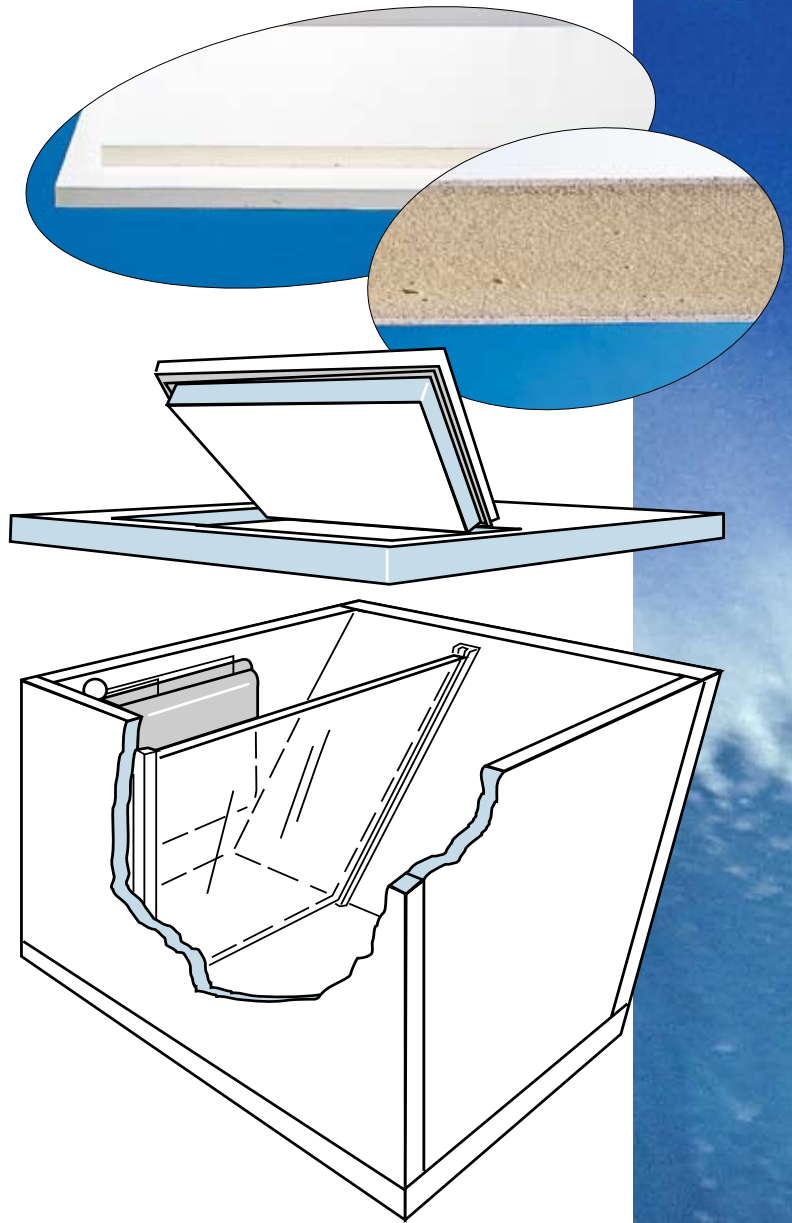

the top part will lay on top of the sides. The box will be more stable.

The lid is cut out from the top part and can either be hinged or loosely. If the lid is made loosely, which is often to prefer, make it either absolute square or obvious rectangular to make handling easy. On top of the lid a plywood or wooden alike plate can be mounted to match the interior.

The insulation ends of the lid has to be protected with plastic strips, they are 2 mm thick, to create a smooth easy to clean surface.

It is important that the lid is well tight, to prevent warm air entering the box. Mount a rubber sealing strip on the lid.

Type

SCD00001AA Kit, three panels 978x478x50 mm



Keeping food on board

The basis for all cooking is fresh and fine groceries. Sharing good food and drink with family and friends on a cruise is always a special occasion.

Provisioning for longer voyages requires larger purchases of perishables. To store the food for the greatest amount of time the temperature must be kept within a correct range, which varies for different kind of foods.

Temperature and storage time to preserve meat, fish and dairy products are:

10°C	Max 1 day
8°C	1-1 1/2 days
6°C	2-3 days
3°C	3-5 days
0-2°C	5-7 days

You will find there are different temperature zones in your refrigeration compartments. Since cold air is heavier than warm air, it is coldest in the bottom and near the evaporator/holding plate. Store sensitive food like meat and fish as close as possible to the evaporator/holding plate. Your vegetables should be stored higher up in the box, away from the evaporator/holding plate.

It is also important to keep your foodstuff as cold as possible while transporting from home or supermarket to the boat.

Deep freezer

For storing food for longer periods of time, deep freezing is necessary. For maximum storage time the freezer must be able to keep the temperature down to -20°C. To store frozen food for shorter periods of time, a temperature of about -12°C is sufficient. There is more information about deep freezer on page 15 and 16.

Insulation

Good insulation in the box is essential. A well-insulated box draws less power and keeps the temperature more constant. A basic rule says 1 mm insulation per litre box volume for a cool box.

Most important is the insulation in the bottom of the box. We recommend using double insulation layers whenever possible. Big deep boxes originally built for holding ice blocks can benefit from adding insulation to the inside to reduce depth. Use polyurethane, polystyrene or equivalent closed cell insulation material.

Isotherm SP Self Pumping Refrigeration System

The Isotherm SP (self-pumping) system for on board refrigeration continues to prove its value for sailors with demands. Since launched 1997 Isotherm SP has been given users all over the world the possibility of refrigeration at extremely low energy-cost, regardless of geographical location. It is carried by a completely unique design and operates on a totally different energy-saving principle to all other refrigeration systems on the market. A technique that took seven years to develop. It has now been used by boat builders, as well as boat owners for several years in the toughest conditions. But still, we get a lot of questions about this matchless way of getting rid of the heat. Some critical and some just by curiosity. Therefore, we have listed these FAQ's (Frequently Asked Questions) below together with our answers and hope that these will be of interest to you.

1. Does it really work? Does not the heated water just flow upwards in the hose for the sink?

Yes – the heated water does rise to waterline level in the hose where it comes to a standstill before rocking up-and-down. This however, has no influence on the cooling effect as an equal volume of water as that rocking up-and-down flow in-and-out through the heat exchanger situated in the skin fitting. Here, every single movement – large or small – of the boat's hull in the water pumps in the same volume of cold water into the heat exchanger as the volume of heated water that has just been sucked out. It is precisely at the orifice of the skin fitting where the heat exchange action occurs – not in the water standing higher up in the hose to the sink. It is for this reason that the inside diameter of the hose at waterline level must be a minimum of 38 mm while that of the orifice in the skin fitting is only 27 mm in diameter. The resultant 2:1 area differential is very important as it creates an appreciable amount of additional turbulence in the orifice.

2. Is such a small heat exchanger coil really large enough to cool the refrigeration system?

Yes – in fact, even if only a piece of tubing the same length as that of the coil had been placed in the water outside the hull, it would still work! The heat however, would then only be transported away by the "thermosiphon effect" of the surrounding water. In the skin fitting heat exchanger of the Isotherm SP, the water flow is also forced away by the self pumping action resulting in an appreciably higher efficiency level.

3. But if I close the seacock? What would happen then?

Turning off the seacock when under sail or engine makes very little difference. When crossing waves and splashing, new water is continually being pushed into the skin fitting even if the seacock is shut. The same thing happens if you are tracking and hear a "gurgling" noise indicating that the ejector effect is sucking the air down from the sink. It works even then! The orifice of the special SP skin fitting is so designed that lateral movement through the water creates a slight over-pressure on one side and correspondingly slight under-pressure on the other side causing the water to splash up into the heat exchanger inside the skin fitting, a principle that also works in planning motor boats. If the seacock is closed in harbour; the refrigeration unit will still operate but at reduced efficiency. This reduction in efficiency, however, is of little importance when shore power is connected but it is preferable that the seacock is open.

4. We sail in warm waters; will not the heat exchanger become blocked by external fouling?

How often must I clean the coil? This is another good thing! You do not get fouling in the skin fitting for the sink if the seacock is open – this fitting is continually being flushed by water. In skin fittings for the engine, toilet or pumps, the water has no movement as they are often blocked by non-return valves, etc. Check this yourself when your boat is on shore next time.

5. If accidentally block up the sink hose with an assortment of spaghetti, rice, potato peelings, etc., what should I do then?

If you were at home, phone for the plumber right away! If you are on your boat and happen to have an Isotherm SP on board, all you have to do is to go sailing. Every single wave you plough through either under sail or motor results in very rapid and

powerful pressure changes in the hose to the sink – so it cleans itself.

6. When in the West Indies, some mucous substance had to be continually removed from both the pump and heat exchanger of our traditional sea water cooled refrigeration unit. Surely this would also occur in an SP?

No, it would not! The water in the SP's skin fitting is always moving even when the refrigerator is switched off. In traditional sea water cooled unit, the water in the system stops moving, for instance, each time the thermostat switches off the refrigerator and the water pump stops. This allows the fouling to start and increase rapidly if light-penetrating transparent hoses have been fitted.

7. Our boat is used for long-distance cruising. When she's on shore for hull cleaning, etc., we usually live aboard. Could we still use our refrigerator?

Yes, it will still work and although it will require much more battery power, this is no problem as adequate shore power is usually connected in this situation. The SP exchanger coil becomes air-cooled using the "chimney effect" created by the flow of warm air rising up through the sink hose. It is important, however, that the drain plug for the sink is always removed after use to increase circulation of the air.

8. But what about corrosion?

The risk of corrosion must always be kept in mind. So-called "noble" metals should always be used for those components which, if they fail, would cause serious damage; when mixing materials consideration must be given to their position on the electro galvanic scale; always fit a sacrificial zinc anode which compensate for the difference in potential. The electrical system of your boat must be checked regularly for current leakage. All Isotherm units have a separate earth and are carefully inspected during production for current leaks. If you have reasons to suspect that there could be a risk of galvanic corrosion aboard, the special sacrificial anode for the SP skin fitting should be checked regularly. Should there be considerable attack and material loss of the anode during a season, the reason for this must be found. The heat exchanger coil of SP is made of a copper/nickel alloy and the skin fitting itself of dezincification-resistant annealed brass certified by Lloyds. The hard-soldering of the connections is in silver.

9. How much less power does a SP or Magnum consume?

Isotherm Sp is available in different version, both with ASU – "Automatic Start Up" in combination with a holding plate, or with a traditional thermostat control and a direct evaporator. In normal northern European waters, an SP-type unit will have a 10-20% lower power consumption compared to that of a corresponding air-cooled unit. In tropical conditions, however, where savings are most needed, power consumption can be reduced by as much as 30-50%. This efficiency increase is largely due to the difference between sea and air temperatures in these waters. Sea water temperatures are normally in region of 25°-30°C, whilst the air temperature inside the boat where the compressor is installed can be 30°, 40° or even 50°C.

10. We want to install both refrigerator and freezer on board. Is it possible to fit two or more units to same skin fitting?

No, it is not – each unit is separate entity and each requires its own heat exchanger skin fitting. These, however, may be connected to the same sink. It is also possible to have one or more heat exchanger skin fitting positioned below the waterline and connected to an existing or additional diameter through-hull air-vent positioned well-above the waterline.

11. We already have a working refrigerator aboard. Is it possible to rebuild it for SP?

Sorry – this is not possible. An SP unit is split into three separate parts, each pre-filled with refrigerant and special re-openable quick coupling. From both an economical and a liability point-of-view it is not convenient to re-build.





Tips

- If possible minimise the load on the refrigerator when the engine is not running by loading in food stuffs that are already chilled.
- Because cooling generates heat, good ventilation of the compressor compartment is essential for air cooled systems. If the temperature in the vicinity of the compressor rises above +40°C, ventilation needs to be improved to allow cool air (preferably from the bilge where the air is coolest) to enter at the bottom and the warm air to leave at the top. A few holes the size of a large coin are usually sufficient. All air-cooled Isotherm units with holding plates are equipped with a fan which speeds up the air flow.
If you have chosen sea water cooled Isotherm SP or Magnum model, high temperature inside the boat is immaterial.
- When the refrigerator is not in use - even for a short period - always leave the door or lid slightly open to avoid unpleasant odours.
- The condensation drain in the box should always be closed when the refrigerator is in operation otherwise the heavier cold air will run out at the bottom to be replaced by lighter warm damp air from the boat.
- It is uneconomical to turn off the refrigerator during the night. In addition to an increase in average power consumption when it is started up again, it is also harmful for the food.

Isotherm and ASU's advantages over other refrigerators

1. Continually senses current refrigeration requirements and level of power available on board.
2. Builds up a supply of cooling energy in the cold-holding plate when a surplus of power is available.
3. Takes advantage first and foremost of the cooling energy already stored instead of consuming battery power.
4. Recognises the difference between various power sources and regulates the system accordingly:
 - 4.1 When the engine is running and a large power surplus is generated under the 5-10 minutes it takes to leave or enter harbour, Isotherm ASU goes into turbo-charger mode to take full advantage of the short power surge.
 - 4.2 If a solar panel or shore-powered battery charger is producing the charge, this is often of low power but is available for a long period. Isotherm ASU registers the difference and allows the compressor (both compressors in TWIN) to run at exactly the correct speed so that batteries and other power-consuming equipment have first priority, but still charges the cold-holding plate somewhat slower so that the temperature in the box does not become too cold. If the solar panel is in shadow for a while, Isotherm then eases off and reduces compressor speed accordingly.
5. Isotherm ASU adjusts itself automatically to suit your refrigeration requirements. Should you load a large amount of warm food into the fridge at the same time, or leave the door open by mistake, the ASU system increases refrigeration capacity only enough to cool the food to a level so that it will not be spoiled.
6. Isotherm ASU does not dither about! Should the level of power available or refrigeration requirements change, the system first waits 30 seconds to see if the change is stable. It then determines what action is required before carrying out its task. The ASU function is also programmed for a fixed "shortest running time" and "shortest stand-still time" so that it does not start and stop unnecessarily thereby reducing its high efficiency factor.
7. An Isotherm ASU system continually adjusts itself to current surroundings. Whether supplied together with a compressor unit to be fitted in a bilge-cooled space on a boat used in Northern waters, or another in Dubai where it will be installed in a hot engine room, the same ASU system senses the difference. It then regulates the speed of the cooling fan or sea water pump to exactly the level required to remove the heat generated by the compressor. This is important as the sound level of the compressors are so low that even the slight amount of noise made by the fan or pump could be heard.
8. Isotherm ASU has low-voltage cut-off and reverse polarity protection, runs on both 12 and 24 volt and has full radio interference suppression.

Isotemp Slim and Basic marine water heaters



Isotemp Slim and Basic are ranges of water heaters, available in eight sizes from 15 to 75 litres volume, made just for marine use, by Indel Marine. 20 years of experience from 30.000: s of Isotemp high quality water heaters have been utilized in the design, material and component choice.

The Isotemp Slim and Basic water heater gives you the following advantages:

- The design both horizontal and vertical mounting options.
- Highest quality in material and welding, 2 years full warranty and 5 years limited warranty on the tank.
- Foamed expanded polyurethane insulation, for lowest temperature loss.
- Immersion heater element, especially designed to heat also the water in the bottom of the tank.
- Engine water heater exchanger coil is extra long for faster heating, good especially for sailing yachts.
- Special 7.0 bar/100 psi safety valve. Simple winter drain.
- All electrical installations ready. A double overheat safety thermostat, only manual resettable. Delivery includes power cable with EU-plug. Service thermostat set to keep the water above 70°C, to prevent the risk of bacteria.
- Stable fixing feet in stainless steel adjustable 360°, for easier also bulkhead installation.
- Thermostat mixing valve available as an option.
- Basic 40 and 75 are also available in versions with double engine water heat exchanger coils for connection also to a water based heater system.

Isotemp Basic has an exclusive look, with its brushed stainless steel cover; but most important is the internal design. The highest capacity is achieved by the engine water heat exchanger as well as the immersion heater placement. They are positioned in the lowest part of the tank where the water is coldest, to really heat all the water in the tank, which grants an outstanding volume of hot water. The water in- and outlets are also designed for a minimal mixing of cold water into the hot, by the incoming water. The selected materials are all the best; tank, tubes and all materials in contact with the water are made of acid proof stainless steel AISI 316 and welded with protection gas to eliminate any risk of corrosion. Each water heater is individually leakage tested to 16 bar/230 psi, before delivery.

Isotemp Slim is a range of water heaters, available in three sizes, 15, 20 and 25 litres. Isotemp Slim has the same exclusive look and design as the Isotemp Basic, with its brushed stainless steel cover. The highest capacity is achieved by the engine water heat exchanger, as well as by the immersion heater mounting. They are positioned as low as possible inside the tank to heat the water where it is coldest.

We give 5 years warranty on the inner tank, for corrosion or material stress! The stainless steel outside cover as well as the mounting feet are made of nonmagnetic stainless steel AISI 304. The Basic 40 and 75 litres water heaters are also available in a special version with double engine water coils for connection to the engine as well as to water based on board heater system.





Isotemp Slim Square

Water heater slim line, in box style is designed for easy installation in narrow spaces on board. The Isotemp Slim Square has a 16 litres capacity, quick and effectively heats water up via the boat engine or by the electrical heater element if the boat is connected to shore power. The water is heated to above 70°C which enables water to be heated on board at the correct levels from both hygiene and safety purpose.

It can be installed in a variety of position, making it more versatile than standard models currently available. As with all Isotemp water heaters, the Isotemp Slim Square has been constructed with a robust acid proof stainless steel (AISI 316) and fitted with special components to protect it from overheating. All electrical installations are factory made and delivered with a cable and plug.

It also features a safety valve for 5.5 bars with a built-in two-way check valve, which reduces or prevents spill water by expansion. It also has a winter drain function. Thermostat mixing valve can be mounted as an option. The safety valve is set to 5.5bar/80 psi on this model.

Technical specification

Article number	Type	Volume lit.	Dimensions* L x ØD x Wmm	Weight kgs	Max pressure bar	Immersion heater**
60153IS000000	Slim 15	15	520 x 295	10.5	7.0	230V/750W
60203IS000000	Slim 20	20	645 x 295	11.5	7.0	230V/750W
60253IS000000	Slim 25	25	765 x 295	13.5	7.0	230V/750W
60243IB000000	Basic 24	24	470 x 395	14.0	7.0	230V/750W
60303IB000000	Basic 30	30	535 x 395	17.0	7.0	230V/750W
60403IB000000	Basic 40	40	640 x 395	20.0	7.0	230V/750W
60403IBD00000	Basic 40 DS Twin coils	40	640 x 395	24.0	7.0	230V/750W
60503IB000000	Basic 50	50	760 x 395	23.0	7.0	230V/750W
60753IB000000	Basic 75	75	1050 x 395	29.0	7.0	230V/750W
60753IBD00000	Basic 75 DS Twin coils	75	1050 x 395	31.0	7.0	230V/750W
60163IQ000000	Square 16	16	400 x 180 x 560	16	5.5	230V/750W

*) Including thermostat mixing valve.

***) Immersion heater 115V/750W also available.

Material: Tank, engine water coil and all connections AISI 316

Outside cover and mounting feet: AISI 304

Electric immersion heater: Copper covered by Nickel

Insulation: Polyurethane

Water connections: 1/2" inside and outside NPT and BSP pipe thread.

Changes of the specification may be done without prior notice.



On board Safes

We have identified a greater need for on board security at a time when an ever-increasing number of boat owners are using more sophisticated and expensive equipment. To help alleviate the potential problem of theft we have safes designed for marine use.

The Isotherm marine safes are available in two sizes, the largest model Safe 30, is big enough in dimensions to store a laptop computer, so often a popular target for thieves. The smaller model, Safe 10 will suit smaller sized electronic equipment such as VHF radios and handheld GPS systems.

Both units are equipped with an electronic code locker with a sharp display and built in battery, so that they can operate independently from external power. When an incorrect code is entered, a warning signal is activated. Should you forget your personal code, both units are also supplied with keys, which can be used in a hidden keyhole, which is exposed only by unscrewing a cover.

Inside the safe, equipment is protected by a soft felt lining. The door of the safe is constructed with 5 mm thick stainless steel and contains two solid locking bars and unbreakable internal hidden hinges.

Technical specification

Safe 10

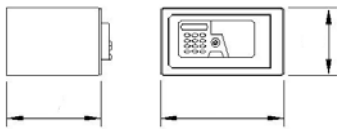

Safe 30

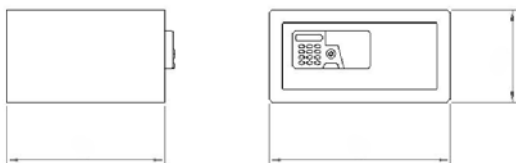

Technical specification

Article Number	Type	Dimensions H x W x D mm	Weight kgs.
7010000A00000	Safe 10	165 x 300 x 230	7
7030000A00000	Safe 30	220 x 430 x 350	19

Specification changes may be done without prior notice.



Isotherm air heater

The hot water-air-heat exchanger transfer the surplus of heat from the engine to warm air, used for defrosting, cabin heating etc. It has a radial fan with three power steps and two turbine rotors. It is equipped with four 60 mm hose brackets for the warm air distribution.

- 10 kW at 80°C water temperature
- Air flow max 500 m³/h
- Power consumption; high power 84W, medium power 54W, low power 45W
- Voltage 12V or 24V
- Weight 5.5 kg
- Water hose connections 16 mm / 5/8"
- Max water pressure 2.5 bar
- Dimensions 450 x 300 x 130 mm

10 kW-12V: **6D01A1DH00000**

10 kW-24V: **6D01B1DH00000**



All Isotherm products are made by Indel Marine,
a company with a tradition in marine refrigeration since the 1960s.
Indel Marine's modern production facility uses the latest technology to
supply what the demanding marine environment really need in quality and
reliability. We have our own distribution plants in Italy, Sweden and USA and
together we serve the marine market world wide through nation
distributors, dealers, marinas, service agents, mail order
and shops.

IT-61019 S. Agata Feltria (PU) Italy
Phone +39 0541 848030
Fax +39 0541 848563
E-mail info@indelmarine.com
www.indelmarine.com
www.isootherm.com

indel
marine