



Specification Sheets for:  
**Refrigerators & Freezers**  
**Do-It-Yourself Cooling Kits**  
**Custom Refrigeration**  
**Eskimo Ice Systems**



Specification Sheets for:  
**Refrigerators & Freezers**  
**Do-It-Yourself Cooling Kits**  
**Custom Refrigeration**  
**Eskimo Ice Systems**

Lit. ID#	Revision Date	Description	Page
<b>REFRIGERATORS/FREEZERS</b>			
2604	12/10/10	CR Series Front-Loading Refrigerators/Freezers	3
2603	05/13/08	RS Series Front-Loading Refrigerators/Freezers	5
2605	05/13/08	RPF-50SS Front-Loading Freezer	7
2607	08/06/10	CF Series Portable Refrigerators/Freezers	9
2691	06/30/09	CB Series Top-Loading Refrigerators/Freezers	11
2690	12/10/10	CD-030 Drawer Refrigerator	13
<b>DO-IT-YOURSELF COOLING KITS</b>			
2693	10/22/10	Adler/Barbour ColdMachine Series	15
2692	06/30/09	CoolMatic Series	17
2694	06/30/09	Adler/Barbour CS-NC-15 Kit	19
<b>CUSTOM REFRIGERATION</b>			
0831	05/28/10	KRA Cabinet Condensing Units	21
2146	10/23/09	Grunert Passagemaker Series	23
0974	05/18/06	Custom Evaporators	25
2148	05/30/06	Dry Evaporator Plates	27
2147	05/30/06	Grunert Holdover Plates	29
<b>ESKIMO ICE SYSTEMS</b>			
2450	08/28/09	Eskimo Ice Fishbox Ice Systems	31
2617	08/21/09	Ice Cube Fishbox Ice System	33

# CR Series Refrigerators/Freezers

## For Your Galley or Cockpit



CR-1080E-S shown  
without flange



**Luxury meets performance and top-of-the-line technology with Dometic's CR Series of premium refrigerators with freezer compartments.** CR refrigerator/freezers are constructed for the rigors of marine use, but designed to compliment any galley or cockpit.

Each CR Series appliance is equipped with a premium Danfoss DC compressor, providing excellent cooling performance, ultra-quiet operation, and minimal power consumption whether operating on DC or AC power. During rough sea conditions, the door remains securely closed—at top and bottom—as a result of the patented double-lock mechanism. The CR's vent mechanism holds the door open slightly for easy defrosting and mildew prevention. The door can be set to open to the left or right to accommodate any galley configuration.



### Award Winning Design

"Beyond pleasing aesthetics, the CR Series compressor refrigerators offer several clever design touches, including a lock to allow the cabinet to ventilate when not in use and a very positive latching mechanism."

— As commented by the awards jury at METS Amsterdam, the world's leading trade show for marine equipment

### Key Benefits

- 12/24 volts DC; 110/220 volts AC.
- Exclusive protected evaporator eliminates the risk of ice-pick damage.
- Cool-blue interior light.
- Diagnostic circuitry installed with green and red LED indicator lights.
- Face panel is interchangeable—even while installed in the boat.
- Four sizes and many colors to choose from.
- Recessed handle provides a smooth, sleek surface.
- Full-width freezer compartment.
- Features include egg tray, bottle holder, extra-large vegetable bin, and adjustable shelves and racks.

## Specification Details for CR Series Refrigerators/Freezers

Model	CR-1050	CR-1065	CR-1080	CR-1110
Freezer Gross Capacity	4.8 quarts (4.5 liters)	4.8 quarts (4.5 liters)	4.8 quarts (4.5 liters)	8.9 quarts (8.4 liters)
Refrigerator Gross Capacity	1.7 cu ft (48.1 liters)	2.3 cu ft (65.1 liters)	2.8 cu ft (79.1 liters)	3.8 cu ft (107 liters)
Voltage	12/24V DC (110/220V AC)	12/24V DC (110/220V AC)	12/24V DC (110/220V AC)	12/24V DC (110/220V AC)
Avg. Power Consumption	40 watts (3.3 amps)	40 watts (3.3 amps)	40 watts (3.3 amps)	45 watts (3.75 amps)
Insulation	CFC-free polyurethane	CFC-free polyurethane	CFC-free polyurethane	CFC-free polyurethane
Compressor	Danfoss BD35F	Danfoss BD35F	Danfoss BD35F	Danfoss BD35F
Refrigerant	Environmentally safe R-134A	Environmentally safe R-134A	Environmentally safe R-134A	Environmentally safe R-134A
Material	Stainless-steel fittings, plastic interior, door frame in plastic body with coated-metal frame	Stainless-steel fittings, plastic interior, door frame in plastic body with coated-metal frame	Stainless-steel fittings, plastic interior, door frame in plastic body with coated-metal frame	Stainless-steel fittings, plastic interior, door frame in plastic body with coated-metal frame
Color Options	<b>CR-1050U/F:</b> black face panel, black door surround, black flush-mount flange <b>CR-1050E/F-W:</b> white face panel, silver door surround, silver flush-mount flange <b>CR-1050E/F-S:</b> stainless-steel face panel, silver door surround, silver flush-mount flange	<b>CR-1065U/F:</b> black face panel, black door surround, black flush-mount flange <b>CR-1065E/F-W:</b> white face panel, silver door surround, silver flush-mount flange <b>CR-1065E/F-S:</b> stainless-steel face panel, silver door surround, silver flush-mount flange	<b>CR-1080U/F:</b> black face panel, black door surround, black flush-mount flange <b>CR-1080E/F-S:</b> stainless-steel face panel, silver door surround, silver flush-mount flange	<b>CR-1110U/F:</b> black face panel, black door surround, black flush-mount flange <b>CR-1110E/F-S:</b> stainless-steel face panel, silver door surround, silver flush-mount flange
*Cut-Out Dimensions with flush-mount flange	16.1" W x 21.3" H x 19.6" D (408mm x 542mm x 497mm)	18.8" W x 21.1" H x 21.3" D (478mm x 537mm x 542mm)	19.9" W x 25.6" H x 20.9" D (505mm x 649mm x 530mm)	21.6" W x 29.8" H x 22.1" D (548mm x 756mm x 560mm)
*Cut-Out Dimensions with space-saver flange	15.1" W x 21.0" H x 17.7" D (383mm x 532mm x 450mm)	17.9" W x 21.1" H x 19.4" D (454mm x 535mm x 494mm)	18.9" W x 25.5" H x 19.0" D (481mm x 648mm x 481mm)	20.6" W x 29.7" H x 20.1" D (523mm x 755mm x 511mm)
Net Weight	42 lbs (19 kg)	46 lbs (20 kg)	52 lbs (23 kg)	62 lbs (28 kg)
Flange Options	EST-0050U: black space-saver EST-0050E: silver space-saver	EST-0065U: black space-saver EST-0065E: silver space-saver	EST-0080U: black space-saver EST-0080E: silver space-saver	EST-0110U: black space-saver EST-0110E: silver space-saver
Replacement Flange Options	EFM-0050U: black flush-mt EFM-0050E: silver flush-mt	EFM-0065U: black flush-mt EFM-0065E: silver flush-mt	EFM-0080U: black flush-mt EFM-0080E: silver flush-mt	EFM-0110U: black flush-mt EFM-0110E: silver flush-mt



■ Premium cooling technology in an elegant design.



■ Patented double-lock door mechanism (indicated by white arrows).



■ Full-length recessed door handle provides comfortable opening and closing.



■ Freezer compartment with door.

### DOMETIC MARINE DIVISION

2000 N. Andrews Ave. Ext. I Pompano Beach, FL 33069 USA | 954-973-2477 | Fax 954-979-4414  
www.DometicUSA.com | MarineSales@DometicUSA.com

### 24/7 Tech Support for United States & Canada:

8:00 AM to 5:00 PM Eastern Time: 800-542-2477  
After hours and weekends: 888-440-4494

### International Sales & Service:

Europe & the Middle East: Call +44(0)870-330-6101  
For all other areas visit our website to find your nearest distributor.



Environmentally Responsible

Dealer:

# Built-In Refrigerator & Freezer

## With Stainless-Steel Interior

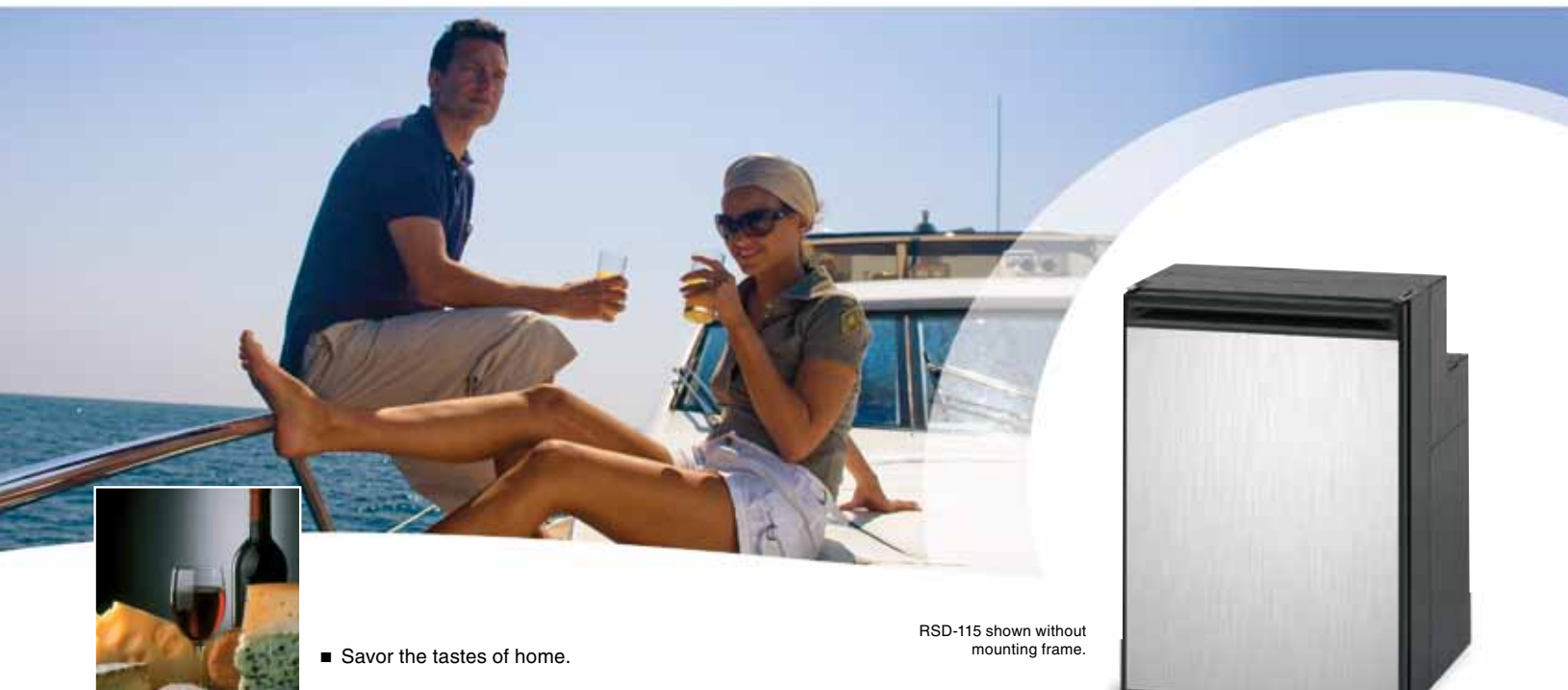

■ Savor the tastes of home.

RSD-115 shown without mounting frame.

**Whether your journeys require reliable refrigeration or deep-freezing capability, the RSD-115 refrigerator and the RSF-115 freezer meet those needs.** Each can be used as a stand-alone installation, or paired to create a cool side-by-side combination.

These attractive built-in units are ideally designed for the rigors of mobile use. A steel frame fitted on all edges keeps the overall body firmly in place. Additional stability is provided by a sturdy steel sheet behind the insulation instead of the typical cardboard fill. The 3.94 cubic-foot refrigerator and the 3.9 cubic-foot freezer are each equipped with a powerful Danfoss compressor.

During rough sea conditions, the door remains securely closed—at top and bottom—as a result of the patented double-lock door mechanism. When not in use, choose the mechanism's vent position, which holds the door open slightly for easy defrosting and mildew prevention. The attractive, unobtrusive, full-width handle provides comfortable opening and closing. Enjoy optimal ease of movement with a door you can set to open left or right to accommodate any galley configuration.

### Key Benefits

- 12/24 volts DC.
- Optional factory-installed adapter for AC operation.
- Danfoss BD35F compressor provides extremely quiet operation.
- Brushed stainless-steel finish.
- Reversible door opening.
- Interior light.
- Choice of standard mount or flush mount flange.

## Specification Details for RSD-115 & RSF-115

Model	RSD-0115E Refrigerator	RSF-0115E Freezer
Gross Capacity	3.94 cubic feet	3.9 cubic feet
Voltage	12/24V DC	12/24V DC
Average Power Consumption	45 watts / 3.3 amps	50 watts / 4.1 amps
Insulation	CFC-free polyurethane	CFC-free polyurethane
Compressor	Danfoss BD35F	Danfoss BD35F
Refrigerant	Environmentally-safe R134A	Environmentally-safe R134A
Material	Stainless-steel fittings, stainless-steel interior, door frame in plastic body with coated metal frame	Stainless-steel fittings, stainless-steel interior, door frame in plastic body with coated metal frame
Color	Stainless-steel face panel, black door surround, black flange	Stainless-steel face panel, black door surround, black flange
Cut-Out Dimensions	20.5"W x 29.12"H x 22"D 520mm x 739mm x 558mm	20.5"W x 29.12"H x 22"D 520mm x 739mm x 558mm
Net Weight	63 lbs / 28.5 kg	63 lbs / 28.5 kg
Interior Light	Yes	Yes
Reversible Door Opening	Yes, left or right	Yes, left or right
AC Adapter Option	MPS-35	MPS-35
Flange Options: Standard Mount, Black Flush Mount, Black	EST-0400 EFM-0400	EST-0400 EFM-0400



- Compressor can be mounted up to five feet away.



- Condensation drain.

## Dimensions for RSD-115 & RSF-115

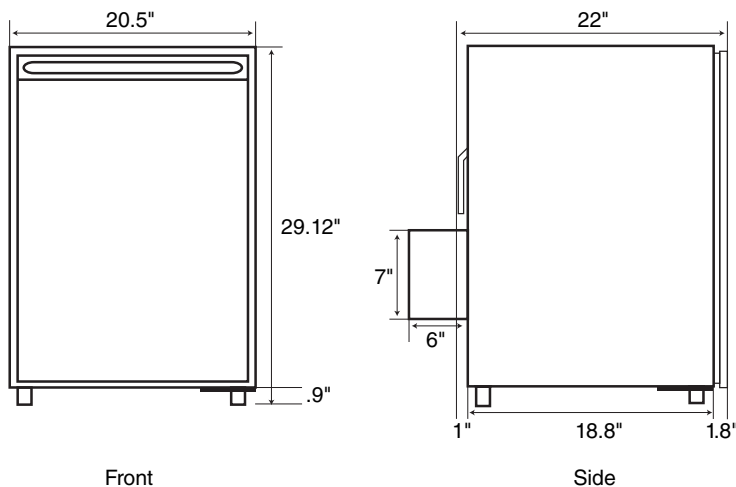

- A powerful side-by-side combo: RSF-115 and RSD-115.

### DOMETIC MARINE DIVISION

2000 N. Andrews Ave. Ext. I Pompano Beach, FL 33069 USA | 954-973-2477 | Fax 954-979-4414  
www.DometicUSA.com | MarineSales@DometicUSA.com

### 24/7 Tech Support for United States & Canada:

8:00 AM to 5:00 PM Eastern Time: 800-542-2477  
After hours and weekends: 888-440-4494

### International Sales & Service:

Europe & the Middle East: Call +44(0)870-330-6101  
For all other areas visit our website to find your nearest distributor.



Environmentally  
Responsible

Dealer:

# Full-Size Built-In Freezer

## With Easy-to-Clean Plastic Interior



■ Frozen treats, anytime.

RPF-50SS shown  
without mounting frame.



**Equipped with a powerful Danfoss compressor, the RPF-50SS offers 1.6 cubic feet of deep-freezing space.** Frozen food is practical and convenient, both at home and on-the-move. But if the freezer compartment in your onboard fridge is too small to accommodate all you want to take on your journey, check out this full-size freezer offered by Dometic. The RPF-50SS can be used as a stand-alone freezer or paired with the same size refrigerator to create a cool side-by-side combination.

During rough sea conditions, the door remains securely closed—at top and bottom—as a result of the patented double-lock door mechanism. When not in use, choose the mechanism's vent position, which holds the door open slightly for easy defrosting and mildew prevention. The attractive, unobtrusive, full width handle provides comfortable use. Enjoy optimal ease of movement with a door you can set to open left or right to accommodate any galley configuration.

### Key Benefits

- 12/24 volts DC.
- Optional factory-installed adapter for AC operation.
- Danfoss BD35F compressor provides extremely quiet operation.
- Brushed stainless-steel finish.
- Condensation drain.
- Reversible door opening.
- Interior light.
- Choice of standard mount or flush mount flange.

## Specification Details for RPF-50SS

Model	RPF-0050SS
Gross Capacity	1.6 cubic feet
Voltage	12/24V DC
Average Power Consumption	40 watts / 3.3 amps
Insulation	CFC-free polyurethane
Compressor	Danfoss BD35F
Refrigerant	Environmentally-safe R134A
Material	Stainless-steel fittings, plastic interior, door frame in plastic body with coated metal frame
Color	Stainless-steel finish face panel, black door surround, black flange
Cut-Out Dimensions	17.5" W x 20.5" H x 21.12" D 444mm x 520mm x 536mm
Net Weight	55 lbs / 25 kg
Interior Light	Yes
Reversible Door Opening	Yes, left or right
AC Adapter Option	MPS-35
Flange Options: Standard Mount, Black Flush Mount, Black	EST-0200 EFM-0200



■ Condensation drain.



■ Easy to clean plastic interior.

## RPF-50SS Dimensions

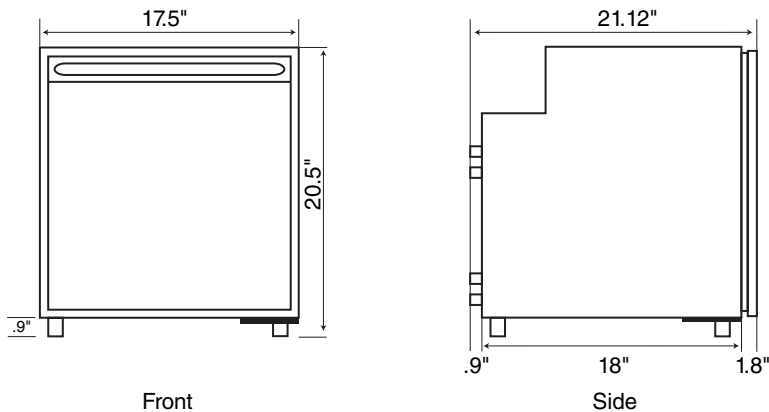

### DOMETIC MARINE DIVISION

2000 N. Andrews Ave. Ext. I Pompano Beach, FL 33069 USA | 954-973-2477 | Fax 954-979-4414  
www.DometicUSA.com | MarineSales@DometicUSA.com

### 24/7 Tech Support for United States & Canada:

8:00 AM to 5:00 PM Eastern Time: 800-542-2477  
After hours and weekends: 888-440-4494

### International Sales & Service:

Europe & the Middle East: Call +44(0)870-330-6101  
For all other areas visit our website to find your nearest distributor.



Environmentally  
Responsible

Dealer:



# CF Series Portable Refrigerators/Freezers

## Refrigerate or Freeze to 0°F



### Charter Fishing Boat Success Story:

"Our savings have been substantial. No more wasted bait since we only thaw out what we need. Thanks!"

— Capt. Roger Wright  
Charter Boat *Rendezvous*, Port Canaveral, FL

CF-18 CF-25 CF-35 CF-40 CF-50 CF-80 CF-110

**CF Series refrigerators/freezers offer powerful cooling and deep-freezing from 50° to 0°F** and state-of-the-art electronics for additional convenience. There's an ideal appliance for every requirement – from the slim 19-quart model to the extra-large capacity 113-quart model. The CF Series features a quick-chill/turbo function which runs the compressor at maximum performance until the desired temperature is reached. All models work perfectly even in inclined positions.



Special electronics include a digital temperature display in Fahrenheit or Celsius. Eight models (CF-25 to CF-110)

are equipped with a unique soft-touch operating panel.

Insulating and Protective Covers with Velcro® closures and zip panels are available for all CF Series Refrigerators/Freezers. Constructed of high-quality Oxford nylon, the covers feature aluminum-coated polyester insulation and a non-skid bottom. The operating panel and connection sockets remain accessible through openings in the cover. Convenient side pockets store small items.

### Key Benefits

- AC/DC or DC-only models.
- Seven sizes to choose from.
- Can operate as a refrigerator or freezer.
- Lightweight and easily portable.
- Battery monitor with low-voltage shut-off protects against a dead battery.
- Memory feature maintains presets if the system is turned off.



- Optional insulated protective cover available for all CF Series models.

Specification Details for the CF Series Portable Refrigerators/Freezers

Model	CF-018DC	CF-025DC	CF-035AC	CF-040AC	CF-050DC	CF-050AC	CF-080AC	CF-110AC	
Gross Capacity (qt./cu. ft.)	19/0.70	24/0.90	33/1.10	39/1.30	52/1.70	52/1.70	85/2.80	113/3.77	
12 oz. Can Capacity	23	27	41	48	68	68	103	144	
Voltage	12/24V DC	12/24V DC	12/24V DC, 100-240V AC	12/24V DC, 100-240V AC	12/24V DC	12/24V DC, 100-240V AC	12/24V DC, 100-240V AC	12/24V DC, 100-240V AC	
Avg. Power Consumption	35 watts, 2.9 amps	35 watts, 2.9 amps	45 watts, 3.75 amps	45 watts, 3.75 amps	45 watts, 3.75 amps	45 watts, 3.75 amps	65 watts, 4.5 amps	65 watts, 4.5 amps	
Insulation	CFC-free polyurethane foam								
Compressor	Danfoss BD35F								
Refrigerant	R-134A								
Cabinet Material	High-impact polypropylene								
Lid Material	Weather-resistant polyethylene								
Color	Pale gray/dark gray								
L x H x W (in/mm)	18.0 x 16.0 x 12.0 457 x 406 x 304	21.7 x 16.7 x 10.2 551 x 424 x 259	22.8 x 15.1 x 14.0 579 x 383 x 355	22.8 x 17.5 x 14.0 579 x 444 x 355	24.8 x 19.4 x 14.0 629 x 492 x 355	24.8 x 19.4 x 14.0 629 x 492 x 355	31 x 18.1 x 19.6 787 x 459 x 497	31.0 x 22.0 x 19.6 787 x 558 x 497	
Net Weight (lbs/kg)	25.0/11.5	27.5/12.5	33.0/15.0	35.0/16.0	40.0/18.0	40.0/18.0	68.0/31.0	73.0/33.0	
Lid	Hinged	Removable	Removable	Removable	Removable	Removable	Hinged	Hinged	
Standard Features	<ul style="list-style-type: none"> <li>• Repositional grid</li> <li>• Carrying handle</li> </ul>	<ul style="list-style-type: none"> <li>• Special electronics</li> <li>• Removable coated-wire basket</li> </ul>	<ul style="list-style-type: none"> <li>• Special electronics</li> <li>• Removable carrying handles</li> <li>• Removable coated-wire grid</li> <li>• Interior light</li> </ul>	<ul style="list-style-type: none"> <li>• Special electronics</li> <li>• Removable carrying handles</li> <li>• Removable coated-wire basket</li> <li>• Interior light</li> </ul>	<ul style="list-style-type: none"> <li>• Special electronics</li> <li>• Removable carrying handles</li> <li>• Removable coated-wire basket</li> <li>• Interior light</li> </ul>	<ul style="list-style-type: none"> <li>• Special electronics</li> <li>• Removable carrying handles</li> <li>• Removable coated-wire basket</li> <li>• Interior light</li> </ul>	<ul style="list-style-type: none"> <li>• Special electronics</li> <li>• Removable carrying handles</li> <li>• Removable coated-wire basket</li> <li>• Interior light</li> </ul>	<ul style="list-style-type: none"> <li>• Special electronics</li> <li>• Removable carrying handles</li> <li>• 2 removable coated-wire baskets</li> <li>• Interior light</li> </ul>	<ul style="list-style-type: none"> <li>• Insulating/protective cover (IC-CF-18)</li> <li>• AC adapter</li> </ul>
Accessories	<ul style="list-style-type: none"> <li>• AC adapter</li> <li>• Insulating/protective cover (IC-CF-18)</li> </ul>	<ul style="list-style-type: none"> <li>• AC adapter</li> <li>• Insulating/protective cover (IC-CF-25)</li> </ul>	<ul style="list-style-type: none"> <li>• Insulating/protective cover (IC-CF-35)</li> </ul>	<ul style="list-style-type: none"> <li>• Insulating/protective cover (IC-CF-40)</li> </ul>	<ul style="list-style-type: none"> <li>• AC adapter</li> <li>• Insulating/protective cover (IC-CF-50)</li> </ul>	<ul style="list-style-type: none"> <li>• Insulating/protective cover (IC-CF-50)</li> </ul>	<ul style="list-style-type: none"> <li>• Insulating/protective cover (IC-CF-80)</li> </ul>	<ul style="list-style-type: none"> <li>• Insulating/protective cover (IC-CF-110)</li> </ul>	



■ The CF-50 fits in most marine slide drawers.

**DOMETIC MARINE DIVISION**  
 2000 N. Andrews Ave. Ext. J Pompano Beach, FL 33069 USA | 954-973-2477 | Fax 954-979-4414  
 www.DometicUSA.com | MarineSales@DometicUSA.com

**24/7 Tech Support for United States & Canada:**  
 8:00 AM to 5:00 PM Eastern Time: 800-542-2477  
 After hours and weekends: 888-440-4494

**International Sales & Service:**  
 Europe & the Middle East: Call +44(0)870-330-6101  
 For all other areas visit our website to find your nearest distributor.



Dealer:

# CB Series Refrigerators/Freezers

## Top-Loading, Space-Saving Built-Ins



CB-036 1.3 cu. ft. unit

CB-040 1.4 cu. ft. unit

**The top-loading CB Series can operate as built-in refrigerators or freezers depending on the temperature you set.** Available in 1.3 cu. ft. (36 liters), 1.4 cu. ft. (39 liters), and 3.5 cu. ft. (100 liters) capacities, these units have energy-efficient Danfoss compressors that run on 12/24V DC power or 110/220V AC power (optional).

A CB unit permanently installs in a cupboard space and continues working even in inclined positions. Its lift-off lid has superior seal and insulation and can accommodate a laminate to match your countertops.



*CB Series refrigerators/freezers feature a convenient space-saving design and an easy-open lid.*

### Key Benefits

- Permanent installation in cupboard space.
- Lid can accommodate laminate to match countertops.
- Ideal for use as a bait freezer or refrigerator.
- Stainless-steel interior housing.
- Impeccable operation in inclined positions.
- Lift-off lid with superior seal and insulation.
- Top loading for improved efficiency and better performance.
- CFC-free polyurethane insulation.
- Variable thermostat allows operation at a wide range of temperatures from refrigeration to freezing.
- Environmentally safe R-134a refrigerant.

## Specification Details for CB Series Top-Loading Refrigerators/Freezers

Model	CB-036	CB-040	CB-110
Gross Capacity	1.3 cu. ft. (36 liters)	1.4 cu. ft. (39 liters)	3.5 cu. ft. (100 liters)
Voltage	12/24V DC 10/220V AC Optional	12/24V DC 10/220V AC Optional	12/24V DC 10/220V AC Optional
Avg. Power Consumption	45 watts/3.75 amps	45 watts/3.75 amps	60 watts/3.75 amps
Insulation	1.6 in. (40mm) solid polyurethane foam	1.6 in. (40mm) solid polyurethane foam	2.0 in. (50mm) solid polyurethane foam
Compressor	Danfoss BD35F	Danfoss BD35F	Danfoss BD35F
Refrigerant	Environmentally safe R-134A	Environmentally safe R-134A	Environmentally safe R-134A
Material	Zinc-coated sheet steel with stainless-steel interior; shock resistant plastic base.	Zinc-coated sheet steel with stainless-steel interior; shock resistant plastic base.	Zinc-coated sheet steel with stainless-steel interior; shock resistant plastic base.
Color	Gray body with dark gray lid.	Gray body with dark gray lid.	Gray body with dark gray lid.
Cut-Out Dimensions (WxHxD)	16.0" x 16.0" x 23.0" <sup>(1)</sup> (406mm x 406mm x 584mm <sup>(1)</sup> )	13.3" x 26.0" x 19.7" (337mm x 660mm x 500mm)	19.1" x 25.6" x 31.7" (485mm x 650mm x 805mm)
Net Weight	41 lbs./18.59 kg.	44 lbs./19.95 kg.	62 lbs./27.9 kg.

Notes:

<sup>(1)</sup> Depth is 16.0" (406mm) if the compressor is mounted remotely.



CB-110 3.5 cu. ft. unit shown

**DOMETIC MARINE DIVISION**

2000 N. Andrews Ave. Ext. I Pompano Beach, FL 33069 USA | 954-973-2477 | Fax 954-979-4414  
www.DometicUSA.com | MarineSales@DometicUSA.com

**24/7 Tech Support for United States & Canada:**

8:00 AM to 5:00 PM Eastern Time: 800-542-2477  
After hours and weekends: 888-440-4494

**International Sales & Service:**

Europe & the Middle East: Call +44(0)870-330-6101  
For all other areas visit our website to find your nearest distributor.



Environmentally  
Responsible

Dealer:

# CD-030 Drawer Refrigerator

## Smart Cooling for Confined Spaces



CD-030 drawer refrigerator shown

**This compact refrigerator turns any unused nook into a practical 31 quart (29 liter) cooler.** The CD-030 permanently installs in any cupboard space. A convenient variable thermostat protects your contents from freezing, and the Danfoss compressor is extremely energy efficient.

For installation flexibility, the compressor can be mounted on the unit's rear, left or right side, or up to 5 ft. (1.5 m) away. The CD-030 drawer refrigerator provides a very energy efficient, flexible solution for boats with limited space.

### Key Benefits

- Permanent installation in cupboard space or under a settee.
- Easy pull drawer on ball-bearing slides.
- Continually variable thermostat prevents contents from freezing.
- Compressor can be mounted on the unit's rear, left or right side, or up to 5 ft. (1.5 m) away.
- Extremely energy efficient.
- Available in black or white.



*The CD-030 converts empty niches in the galley or under a settee into a 30-liter capacity refrigerator.*

## Specification Details for CD-030 Drawer Refrigerator

Model	CD-030DC
Gross Capacity	31 quarts/29 liters
Voltage	12/24V DC 10/220V AC Optional
Average Power Consumption	40 watts/3.3 amps
Insulation	CFC-free polyurethane
Compressor	Danfoss BD35F
Refrigerant	Environmentally safe R-134A
Material	Sturdy metal housing with injection-molded parts
Color Options	<b>CD-030DC-D65A:</b> Black drawer <b>CD-030DCW-D65A:</b> White drawer
Cut-Out Dimensions (WxHxD)	17.0" x 9.8" x 28.7" <sup>(1)</sup> (431mm x 248mm x 728mm <sup>(1)</sup> )
Net Weight	44 lbs./19.95 kg.

Notes:

<sup>(1)</sup> Depth is 20.0" (508mm) if the compressor is mounted remotely.

**DOMETIC MARINE DIVISION**

2000 N. Andrews Ave. Ext. I Pompano Beach, FL 33069 USA | 954-973-2477 | Fax 954-979-4414  
www.DometicUSA.com | MarineSales@DometicUSA.com

**24/7 Tech Support for United States & Canada:**

8:00 AM to 5:00 PM Eastern Time: 800-542-2477  
After hours and weekends: 888-440-4494

**International Sales & Service:**

Europe & the Middle East: Call +44(0)870-330-6101  
For all other areas visit our website to find your nearest distributor.



Environmentally  
Responsible

Dealer:

# Adler/Barbour ColdMachine Kits

## Customized Do-It-Yourself Refrigeration

New Quick-Connect Hoses



CU-100 ColdMachine & VD-150 Evaporating Unit (shown with ice trays)

**Performance, efficiency, and quality are hallmarks of Adler/Barbour ColdMachine Kits by Dometic.** Two configurations are offered: The air-cooled CU-100 ColdMachine, and the air- and water-cooled CU-200 SuperColdMachine. Powered by a Danfoss BD50F compressor, these easy-to-install units provide up to 15 cu. ft. (424 liters) of refrigeration and work with a variety of 100-Series evaporators (see reverse side).

ColdMachines are specifically designed to survive the rigors of the harsh marine environment, and to provide exceptional performance in hot and humid conditions, erratic or low voltage, and continuous use.

ColdMachine kits now come with self-sealing quick-connect fittings for easy attachment. Unlike the old “one-shot” connections, quick-connect fittings can be disconnected and reconnected whenever necessary without loss of refrigerant or exposing the system to air or moisture.

Dometic also offers quick-connect adapters (shown below), which join “one-shot” units to their quick-connect counterparts (professional installation required).

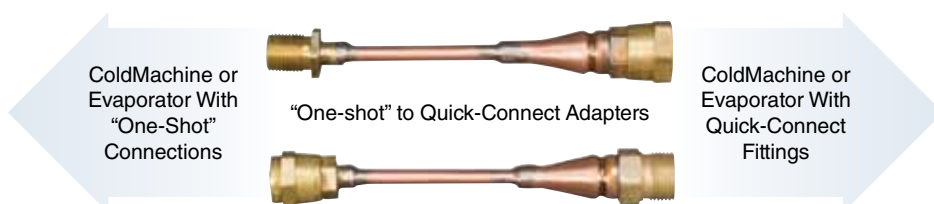

ColdMachine or Evaporator With “One-Shot” Connections

“One-shot” to Quick-Connect Adapters

ColdMachine or Evaporator With Quick-Connect Fittings

### Key Benefits

- Now with self-sealing quick-connect fittings.
- Oversized air condensers.
- Up to 15 cu. ft. (424 liters) of refrigeration.
- Danfoss BD50F compressor provides 25% more cooling performance.
- Stainless-steel construction.
- Shrouded forced-air condensers.
- Modular phone-jack connection for thermostat.
- Quick-connect adapters keep older “one-shot” units in service.
- Optimal performance in warmer waters.
- High-CFM fan.
- Built-in troubleshooting diagnostics.
- Environmentally safe R-134a refrigerant.
- Can be installed up to 15 ft. (4.57 m) from evaporator.
- Precharged and ready to install.

## Technical Specifications for Adler/Barbour ColdMachine Cooling Units

Model	CU-100 ColdMachine	CU-200 SuperColdMachine
Capacity	15.0 cu. ft. (424 liters)	15.0 cu. ft. (424 liters)
Voltage	12V DC	12V DC
Application	General Boating	Tropical-Water Boating
Dimensions (WxHxD)	10.0 in. x 7.5 in. x 11.1 in. (254mm x 190mm x 281mm)	10.0 in. x 7.5 in. x 11.1 in. (254mm x 190mm x 281mm)
Net Weight	18 lbs./8.2 kg.	18 lbs./8.2 kg.



Adler/Barbour  
CU-200 ColdMachine

## Technical Specifications for Adler/Barbour 100 Series Evaporating Units

Model	VD-150	VD-151	VD-152
Capacity	9.0 cu. ft. (254 liters)	9.0 cu. ft. (254 liters)	15.0 cu. ft. (424 liters)
Application	Medium-sized refrigerator to small freezer	Medium-sized refrigerator to small freezer	Large-sized refrigerator to medium freezer
Configuration	Closed evaporator	Closed evaporator with door	Closed evaporator
Dimensions (WxHxD)	10.5 in. x 11.0 in. x 6.0 in. (266mm x 279mm x 152mm)	10.75 in. x 7.0 in. x 11.25 in. (273mm x 177mm x 285mm)	15.0 in. x 12.0 in. x 6.0 in. (381mm x 304mm x 152mm)
Net Weight	12 lbs. (5.4 kg.)	10 lbs. (4.5 kg.)	13 lbs. (5.9 kg.)
Image			
Model	VD-153	VD-160	Optional Water-Cooling Kit
Capacity	15.0 cu. ft. (424 liters)	4 cu. ft. (113 liters)	Simplify water cooling installation for your CU-200 SuperColdMachine. Kit includes 12V DC water pump and mounting bracket, 5 ft. of 5/8" hose, 10 ft. of 3/8" hose, hose clamps, seawater strainer, 5/8" plastic through-hull discharge fitting, wiring diagram and mounting screws. Pump draws less than 1A and must be plumbed to a seawater source for operation. <b>P/N #C8350</b>
Application	Large-sized refrigerator to medium freezer	Medium- to small-sized freezer	
Configuration	Closed evaporator with door	Power plate with holdover capabilities	
Dimensions (WxHxD)	15.5 in. x 7.5 in. x 12.0 in. (393mm x 190mm x 304mm)	19.0 in. x 11.25 in. x 1.25 in. (482mm x 285mm x 31mm)	
Net Weight	14 lbs. (6.4 kg.)	23 lbs. (10.4 kg.)	
Image			

### DOMETIC MARINE DIVISION

2000 N. Andrews Ave. Ext. I Pompano Beach, FL 33069 USA | 954-973-2477 | Fax 954-979-4414  
www.DometicUSA.com | MarineSales@DometicUSA.com

### 24/7 Tech Support for United States & Canada:

8:00 AM to 5:00 PM Eastern Time: 800-542-2477  
After hours and weekends: 888-440-4494

### International Sales & Service:

Europe & the Middle East: Call +44(0)870-330-6101  
For all other areas visit our website to find your nearest distributor.



Dealer:



# CoolMatic Cooling Kits

## Customized Do-It-Yourself Refrigeration



Dometic CU-86  
condensing unit shown

**Performance, efficiency, and quality are hallmarks of the CoolMatic 80 Series by Dometic.** Compact, easy-to-install CoolMatic units are designed to provide up to 8.8 cu. ft. (249 liters) of refrigeration or up to 2.5 cu. ft. (65 liters) of deep freezing. Powered by a Danfoss BD35F compressor, the versatile CoolMatic Series offers three different configurations for installation flexibility and tailor-made cooling applications.

These cooling units are designed to work with CoolMatic 80 Series Evaporating units. Six configurations are offered (see reverse side) to match the performance of the compressor.

The CoolMatic Series is specifically designed to survive the rigors of the harsh marine environment, and to provide exceptional performance in hot and humid conditions, erratic or low voltage, and continuous use.

### Key Benefits

- Designed for small to medium refrigerator or small freezer capacities.
- Designed to work in warmer waters.
- Corrosion-resistant stainless-steel mounting plate.
- Applications up to 8.8 cu. ft. (249 liters) of refrigeration and up to 2.5 cu. ft. (65 liters) of deep freezing.
- Equipped with a power-regulated Danfoss BD35F compressor.
- Environmentally-safe R-134a refrigerant.
- Six evaporator types to match the performance of the compressor (details on reverse side).





CU-84





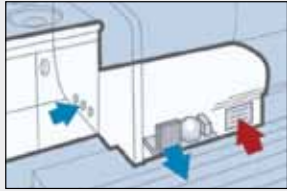

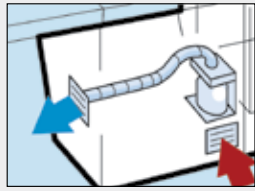
CU-85

## Technical Specifications for CoolMatic 80 Series Cooling Units

Model	CU-84	CU-85	CU-86
Capacity	Refrigeration: 8.83 cu. ft. (250 liters) Deep freezing: 2.47 cu. ft. (70 liters)	Refrigeration: 8.83 cu. ft. (250 liters) Deep freezing: 2.47 cu. ft. (70 liters)	Refrigeration: 8.83 cu. ft. (250 liters) Deep freezing: 2.47 cu. ft. (70 liters)
Voltage	12/24V DC	12/24V DC	12/24V DC
Configuration	Horizontal Platform	Square Layout	Vertical or Wall Mount
Dimensions (WxHxD)	15.2 in. x 6.1 in. x 5.1 in. (386mm x 155mm x 129mm)	8.7 in. x 6.1 in. x 8.7 in. (220mm x 155mm x 220mm)	8.7 in. x 9.0 in. x 7.6 in. (220mm x 228mm x 193mm)
Net Weight	13.2 lbs. (5.98 kg.)	13.2 lbs. (5.98 kg.)	14.3 lbs. (6.40 kg.)
Installation			

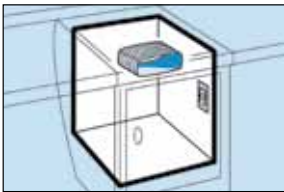
## Technical Specifications for Adler/Barbour 80 Series Evaporating Units

Model	VD-04	VD-05	VD-08
Capacity	4.5 cu. ft. (127 liters)	4.5 cu. ft. (127 liters)	5.6 cu. ft. (158 liters)
Configuration	"L" shape	Plate	90° Angle
Dimensions (WxHxD)	14.8 in. x 10.0 in. x 3.9 in. (377mm x 254mm x 99mm)	14.8 in. x 13.7 in. x 1.0 in. (375mm x 348mm x 25.4 mm)	13.4 in. x 17.7 in. x 10.6 in. (340mm x 449mm x 269mm)
Net Weight	3.3 lbs. (1.49 kg.)	3.3 lbs. (1.49 kg.)	4.4 lbs. (1.99 kg.)
Installation			
Model	VD-09	VD-15	VD-18
Capacity	5.6 cu. ft. (158 liters)	7.0 cu. ft. (198 liters)	4.5 cu. ft. (127 liters)
Configuration	"O" shape	Circulating Air	Plate
Dimensions (WxHxD)	14.4 in. x 5.5 in. x 10.6 in. (365mm x 139mm x 269mm)	8.6 in. x 10.8 in. x 2.6 in. (218mm x 274mm x 66mm)	9.8 in. x 13.7 in. x 1.0 in. (248mm x 347mm x 25.4mm)
Net Weight	4.4 lbs. (1.99 kg.)	4.4 lbs. (1.99 kg.)	3.1 lbs. (1.40 kg.)
Installation			

**DOMETIC MARINE DIVISION**

2000 N. Andrews Ave. Ext. | Pompano Beach, FL 33069 USA | 954-973-2477 | Fax 954-979-4414  
www.DometicUSA.com | MarineSales@DometicUSA.com

**24/7 Tech Support for United States & Canada:**

8:00 AM to 5:00 PM Eastern Time: 800-542-2477  
After hours and weekends: 888-440-4494

**International Sales & Service:**

Europe & the Middle East: Call +44(0)870-330-6101  
For all other areas visit our website to find your nearest distributor.



Environmentally  
Responsible

Dealer:

# CS-NC-15 Cooling Kit

## Super Compact and Easy-to-Install



CoolMatic CS-NC-17  
Cooling Kit shown

**The CS-NC-15 compact cooling kit consists of the high-performance air-circulating VD-15 fin evaporator and the power-regulated CoolMatic cooling unit.** These two units in one kit offer a perfect match of rapid-chill capability and high cooling performance.

The tried and tested Danfoss BD35F compressor ensures economical and super quiet operation. This cooling unit is specifically designed for chest coolers with capacities from 2.12 cu. ft. (60 liters) for deep freezing to 8.8 cu. ft. (249 liters) for normal refrigeration.

Installation is quick and easy. All that's required is a hole cut to match the size of the cooling kit. The CS-NC-15 is then simply screwed from inside to the mounting plate.

### Key Benefits

- Ideal for converting an existing, passive, insulated cooling area into a full, compressor-powered refrigerator.
- Up to 8.8 cu. ft. (249 liters) of refrigeration.
- Rapid chill capability with forced air circulation operation.
- Efficient Danfoss BD35F compressor.
- Vertical layout or wall mount.
- Integrated low voltage protection.
- Continuously variable thermostat.
- Integrated rubber seal ensures that the coolbox is securely sealed.
- Coolant lines are fully assembled and connected at the factory.
- Environmentally-safe R-134a refrigerant.

## Technical Specifications for Adler/Barbour CS-NC-15 Cooling Kit

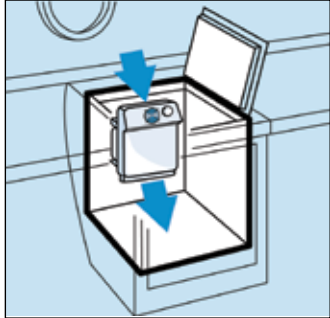
Model	CS-NC-15
Capacity	Deep Freezing: 2.12 cu. ft. (60 liters) Refrigerating: 8.8 cu. ft. (249 liters)
Voltage	12/24V DC
Dimensions (WxHxD)	10.6 in. x 14.3 in. x 8.9 in. (258mm x 363mm x 227mm)
Net Weight	14 lbs. (6.35 kg.)
Installation	

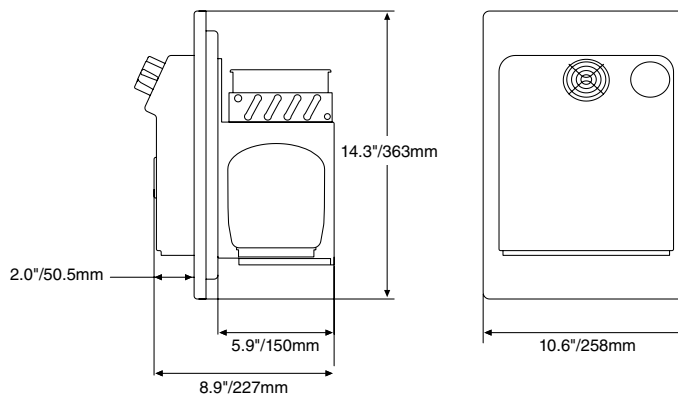

**DOMETIC MARINE DIVISION**

2000 N. Andrews Ave. Ext. I Pompano Beach, FL 33069 USA | 954-973-2477 | Fax 954-979-4414  
www.DometicUSA.com | MarineSales@DometicUSA.com

**24/7 Tech Support for United States & Canada:**

8:00 AM to 5:00 PM Eastern Time: 800-542-2477  
After hours and weekends: 888-440-4494

**International Sales & Service:**

Europe & the Middle East: Call +44(0)870-330-6101  
For all other areas visit our website to find your nearest distributor.



Environmentally  
Responsible

Dealer:

**New Low-Profile  
Models Available!**

# KRA Cabinet Condensing Units

## For Use In Refrigeration & Freezer Systems



KRA025 water-cooled-only unit shown

**KRA cabinet condensing units are designed for use in direct expansion refrigeration and freezer systems**, such as cockpit freezers/refrigerators or catch-box chillers (not holdover plate systems), and can also be used with built-in galley freezer/refrigerators. KRA units work in conjunction with evaporator plates installed in an insulated box, or a box wrapped with evaporator tubing. Box temperatures between  $-5^{\circ}\text{F}$  and  $40^{\circ}\text{F}$  ( $-20^{\circ}\text{C}$  and  $5^{\circ}\text{C}$ ) can be achieved with the proper application.

KRA condensing units are housed in an attractive white aluminum enclosure, which can be mounted on a vertical bulkhead or a horizontal shelf. An integral drain pan allows any condensate to be routed to the bilge or sump.

Units are available with 1/4, 3/8, and 1/2 HP compressors, and 115V 50/60Hz or 220V 50Hz. All KRAs have a durable cupronickel water-cooled condenser. Units are available in two condenser configurations: Air/water-cooled or water-cooled only. This dual configuration will ensure that the unit performs efficiently in hot engine rooms, while also allowing full air-cooled operation when no cooling water is available.

### New Low-Profile Models

The water-cooled-only models are available in a new, compact, low-profile design. At 11" (280mm) tall, these units are 4.75" (121mm) shorter and 10 pounds (4.5kg) lighter than before. In addition, the re-configuration of the terminal strip and additional access covers enable easier installation and maintenance.

ISO 9001:2008

L-0831 Rev. 20100528

### Key Benefits

- Refrigeration/freezer condensing unit in attractive white aluminum enclosure.
- Air/water-cooled or water-cooled-only condensers available.
- Low-profile models available.
- Can be mounted on a vertical bulkhead or a horizontal shelf.
- Drain pan allows any condensate to be routed to the bilge or sump.
- 1/4, 3/8, and 1/2 HP compressors available.
- 115V 50/60Hz and 220V 50Hz models.
- Self-sealing, quick connect fittings.
- Charged with leak-detector dye.
- Digital thermostats available.
- Optional pre-charged refrigerant lines, in copper or flexible hose, available in lengths up to 25' (7.62m).
- Optional dual-box system provides two different boxes to be set at two different temperatures using only one condensing unit.

**Cruisair<sup>®</sup>**  
by Dometic GROUP

## Technical Specifications for KRA Cabinet Condensing Units

Model	KRA025	KRA025 Water-Cooled Only	KRA025CK	KRA025CK Water-Cooled Only	KRA038	KRA038 Water-Cooled Only	KRA038CK	KRA038CK Water-Cooled Only	KRA050
Horsepower	1/4	1/4	1/4	1/4	3/8	3/8	3/8	3/8	1/2
Volts/Hz/Phase	115/60/1	115/60/1	220/50/1	220/50/1	115/60/1	115/60/1	220/50/1	220/50/1	115/60/1
Locked Rotor Amps (Comp)	40.0	40.0	14.8	14.8	40.0	40.0	17.5	17.5	68.0
Max. Circuit Breaker (Amps)	15.0	15.0	5.0	5.0	15.0	15.0	10.0	10.0	25.0
Min. Circuit Ampacity (Amps)	11.0	11.0	4.0	4.0	11.0	10.0	5.0	5.0	15.0
Full Load Amps (FLA) Cool	6.2	5.8	3.1	2.9	6.5	6.1	3.2	3.0	8.5
Width (in/mm)	14.25/362	14.25/362	14.25/362	14.25/362	14.25/362	14.25/362	14.25/362	14.25/362	16.1/409
Depth (in/mm)	8.75/222	8.75/222	8.75/222	8.75/222	8.75/222	8.75/222	8.75/222	8.75/222	10.3/262
Height (in/mm)	14.75/375	11.00/279	14.75/375	11.00/279	14.75/375	11.00/279	14.75/375	11.00/279	17.50/445
Weight (lbs/kg)	50/22.7	40/18.1	50/22.7	40/18.1	51/23.1	41/18.6	51/23.1	41/18.6	65/29.5

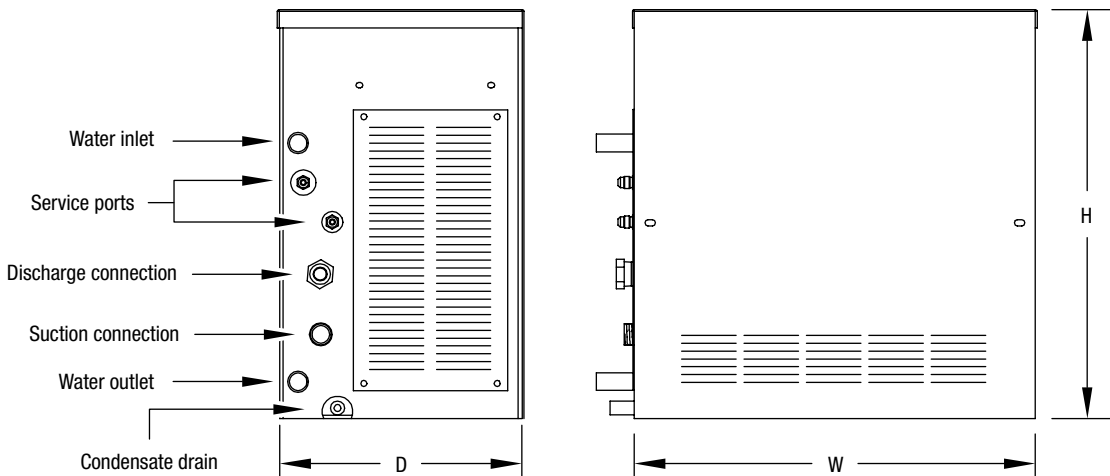

**DOMETIC MARINE DIVISION**

2000 N. Andrews Ave. Ext. I Pompano Beach, FL 33069 USA | 954-973-2477 | Fax 954-979-4414  
 www.DometicUSA.com | MarineSales@DometicUSA.com

**24/7 Tech Support for United States & Canada:**

8:00 AM to 5:00 PM Eastern Time: 800-542-2477  
 After hours and weekends: 888-440-4494

**International Sales & Service:**

Europe & the Middle East: Call +44(0)870-330-6101  
 For all other areas visit our website to find your nearest distributor.



Environmentally Responsible

Dealer:

# Grunert Passagemaker Series

## AC Operation Refrigeration Systems



Passagemaker AC450  
model shown

**Grunert Passagemaker compressors are hermetically sealed for quiet, efficient operation.** Vibration isolators are incorporated in all mounting platforms to provide additional noise reduction.

### Key Benefits

- Filter/drier is replaceable without refrigerant charge loss.
- Effectively cools one or multiple boxes of virtually any configuration.
- Sight glass / moisture indicator assembly to monitor system refrigerant charge.
- Remote electrical box is completely enclosed to protect all components.
- 5' (1.5 m) harness allows for a dry, accessible mounting location.
- Low 12 voltage controls provide an extra margin of safety.
- Hermetically sealed compressor for quiet, efficient operation.
- Vibration isolation mounts for additional noise reduction.
- Charge Guard® protection provides sealed access ports to ensure system integrity during handling and installation.

# Technical Specifications for Passagemaker Series

Model <sup>1</sup>	AC425	AC450	AC475	AC4100Z	AC4150Z	AC4200Z
Refrigerant	R-404A	R-404A	R-404A	R-404A	R-404A	R-404A
Charge (oz./g.)	26/737	50/1420	50/1420	50/1420	76/2152	76/2152
<b>Capacity (BTU/hr)<sup>2</sup></b>						
26°F (-3°C)	1850	3400	5000	6500	9000	15000
0°F (-18°C)	1650	2800	4200	5500	7000	11900
-9°F (-23°C)	1500	2200	3600	4500	5500	9350
-18°F (-28°C)	1250	1800	3200	3900	4800	480
<b>Electrical Data</b>						
RLA - 115V/230V (water-cooled)	5.9/2.9	6.7/3.0	15.2/7.7	- /10.9	- /10.9	- /18.6
RLA - 115V/230V (air/water-cooled)	6.9/3.4	7.7/3.5	16.2/8.2	- /11.4	- /11.4	N/A
LRA - 115V/230V	40.0/20.5	68.0/34.0	59.0/37.0	- /56.0	- /56.0	- /107.0
Max. Circ. Breaker 115V/230V	15.0/10.0	20.0/10.0	35.0/15.0	- /25.0	- /30.0	- /40.0
Min. Circ. Ampacity 115V/230V	10.0/5.0	16.0/7.0	27.0/14.0	- /20.0	- /20.0	- /30.0
<b>Unit Dimensions (in/mm)</b>						
D (Depth) <sup>4</sup>	14.1/358	14.1/358	14.1/358	20.0/508	20.0/508	20.0/508
W (Width) <sup>5</sup>	13.1/334	13.1/334	13.1/334	17.0/432	17.0/432	17.0/432
H (Height)	10.5/267	13.6/346	14.8/375	15.3/387	15.3/387	16.0/406
<b>Electrical Box Dimensions (in/mm)</b>						
D (Depth)	10.875/276					
W (Width)	10.625/270					
H (Height)	4.0/102					
<b>Weight (lbs/kg)<sup>6</sup></b>						
Net	47.0/21.3	78.0/35.4	74.0/33.6	75.0/34.0	77.0/34.9	92/41.7
Ship	63.0/28.6	94.0/42.6	92.0/41.7	93.0/42.2	95.0/43.1	110/49.9

Notes:

- <sup>1</sup> Add a 'Z' to the model number to indicate 230 VAC for models AC425 through AC475. Also add HA to model numbers for air cooled option (not available on AC4200Z).
- <sup>2</sup> BTU/hr. ratings are the average rate of heat extraction from holdover plates and are not the capacity of the compressor or condensing unit. These figures are to be used to determine run times required to maintain box design temperatures.
- <sup>3</sup> Physical dimensions of 50Hz models may vary.
- <sup>4</sup> Add 2" (51 mm) for condensate hose connector. Add additional 10.75" (273 mm) for air cooled option.
- <sup>5</sup> Add 1/2" to width for air cooled option on AC425-475HA.
- <sup>6</sup> Add 8 lbs (3.6kg) for remote electrical box. Add 20-30 lbs. for air cooled option. All weights include refrigerant charge. Ship weights include electric boxes.

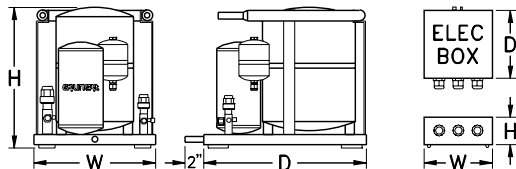
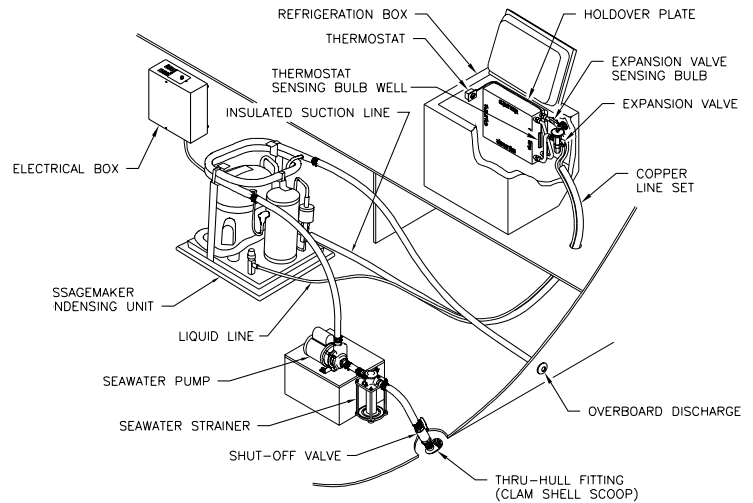

**DOMETIC MARINE DIVISION**

2000 N. Andrews Ave. Ext. I Pompano Beach, FL 33069 USA | 954-973-2477 | Fax 954-979-4414  
 www.DometicUSA.com | MarineSales@DometicUSA.com

**24/7 Tech Support for United States & Canada:**

8:00 AM to 5:00 PM Eastern Time: 800-542-2477  
 After hours and weekends: 888-440-4494

**International Sales & Service:**

Europe & the Middle East: Call +44(0)870-330-6101  
 For all other areas visit our website to find your nearest distributor.



Environmentally Responsible

Dealer:



# Custom Evaporators

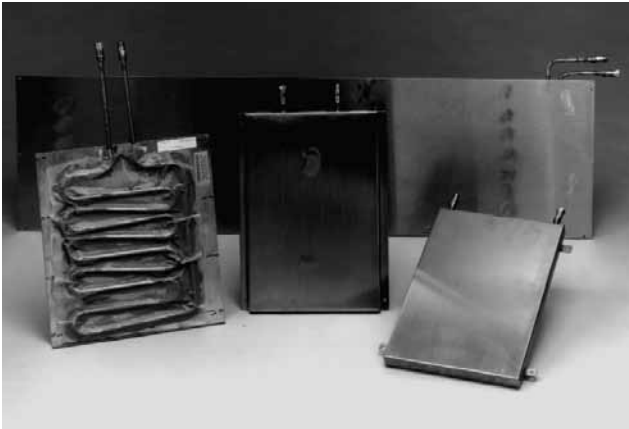

Custom Stainless Flat Plates Shown

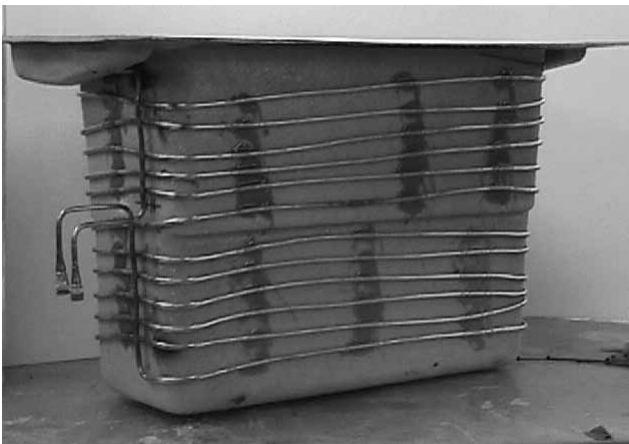

Custom Wrapped Box Evaporators Shown

## Custom Flat Plate Evaporators

Custom stainless steel plates are available for installation into an insulated box. The plates have stainless tubing with special heat transfer compound to improve efficiency. Rectangular plates of any dimension from 10" - 36" (254mm - 914mm) are available. Plate size is chosen to maximize the surface area in the box, with a minimum of 40% of the inside wall area covered. Plates are pre-charged with R-134A, and have quick connect fittings. Plates without charge are also available.

## Custom Wrapped Box Evaporators

Cruisair custom wrapped boxes are ideal for use where a clean box interior is necessary, although almost any refrigeration application can be built. Using the wrapped box as bait freezers or catch boxes helps keep the items from freezing to the evaporator surface, and aids in cleaning of the box. The fiberglass box is wrapped with copper tubing and pre-charged with R-134A at the factory. A special heat transfer compound is used to help heat transfer from the box to the tubing. All boxes are supplied with quick connect fittings to speed installation. In fact, Cruisair can offer a turn-key product: the fiberglass box per your design, wrapped with tubing and insulated.

Pre-charged 3/8" copper tubing for wrapping boxes is also available in lengths of 50' - 150' (15.2m - 45.7m).

Contact the applications department for help in designing your refrigeration system.

## Key Benefits

### Custom Wrapped Box

- Inside of freezer box is free of all refrigeration equipment, and has a clean look.
- Less holes through box mean less chance of content leakage.
- There are no plates for food, bait, or catch to freeze on.
- Easy cleaning of box.
- Excellent performance as a freezer or refrigerator.
- Factory sealed refrigerant connections of evaporator tubing.
- Cruisair will help design the box that will fit your needs.
- Cruisair can build a turn-key unit which includes the fiber glass box, tubing wrap, and insulation.

### Custom Flat Plates

- Cruisair custom stainless steel refrigeration plates can be the answer to refrigeration of your fish box, cockpit freezer, drink box, bait freezer, or any other custom refrigeration needs.

- Refrigeration plates can be built to the exact dimensions of each particular box requirement.
- Cruisair refrigeration plates are ideal for both freezer and refrigeration applications.
- Refrigeration plates are constructed of durable 18 gauge 304 stainless steel which will resist corrosion from harsh environments and damage from objects in the box.
- Total thickness of plate is held to a max. of 5/8" which allows for use of virtually all of the interior of the box.
- Refrigerant tubing is spot welded to the underside of the plate. The tubing is 3/8" stainless steel, so it also resists corrosion from harsh environments.
- Cruisair will help with box design, thickness, condenser sizing and plate sizing.

### Specifying Your Custom Flat Plate Evaporators

To Determine what size plates you will need to order, first decide where you can place the plates in the box to maximize plate surface area. Plate surface area should be at least 40% of the box's total surface area, which means adding all six sides of the inside of the box into the equation. Less plate surface can be used when box is operating only as a refrigerator (35°F+).

For example, a box that is 20" long, 20" deep, and 10" wide has a total of 1600 sq. inches. Forty percent of 1600 sq. inches is 640 sq. inches, so we

will need plates to cover at least 640 sq. inches. If we pick the two ends, that only gives about 400 sq., but if we cover the two sides that are 20" x 20", we have about 800 sq. inches to cover. This would give enough plate surface area to efficiently cool the box.

When ordering, be sure to specify length and width of plate, where the refrigerant lines need to come out of the plate, and length of the lines.

Contact the applications department for help in designing your refrigeration system.

#### DOMETIC MARINE DIVISION

2000 N. Andrews Ave. Ext. I Pompano Beach, FL 33069 USA | 954-973-2477 | Fax 954-979-4414  
www.DometicUSA.com | MarineSales@DometicUSA.com

#### 24/7 Tech Support for United States & Canada:

8:00 AM to 5:00 PM Eastern Time: 800-542-2477

After hours and weekends: 888-440-4494

#### International Sales & Service:

Europe & the Middle East: Call +44(0)870-330-6101

For all other areas visit our website to find your nearest distributor.



Environmentally  
Responsible

Dealer:

# Dry Evaporator Plates

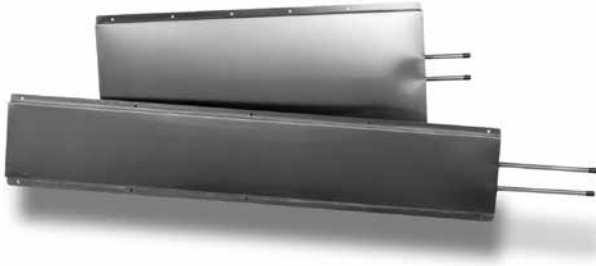

## Features

- Grunert stainless steel dry Evaporator Plates provide an effective solution for cooling cockpit freezers, drink boxes and custom refrigeration applications.
- Evaporator plates are a cost effective solution when holdover systems are not required.
- Evaporator plates can be specified for both refrigeration and/or freezer applications.
- Minimal plate thickness (9/16") allows for a clean, wall to wall installation inside any box.
- Plates are constructed of 20 gauge #304 stainless steel for strength and a #3 finish for aesthetics.
- Refrigerant connections are constructed of 3/8" O.D. copper tube. Optional flare quick disconnect (QD) or swagelok fittings are available upon request.
- Properly sized plates will rapidly lower and thermostatically maintain box temperature on demand. Properly insulated boxes will maintain desired temperatures with minimum compressor duty cycles.

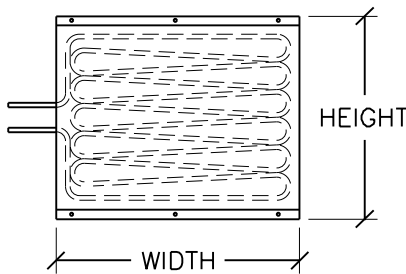

HORIZONTAL PLATE

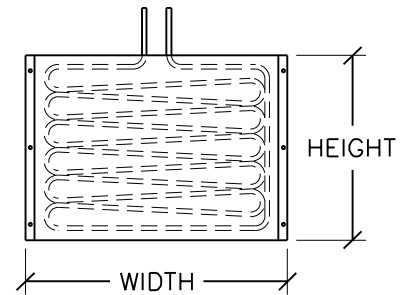

VERTICAL PLATE

CAPACITIES IN BTU/Hr, DIMENSIONS IN INCHES

		HORIZONTAL PLATE WIDTH*									
		8	12	16	20	24	28	32	36	40	44
HORIZONTAL PLATE HEIGHT*	7.50	9	14	18	23	28	32	37	41	46	50
	9.75	13	19	25	32	38	44	50	57	63	69
	12.00	16	24	32	40	48	56	64	72	80	88
	14.25	19	29	39	49	58	68	78	88	97	107
	16.50	23	34	46	57	69	80	92	103	115	126
	18.75	26	40	53	66	79	92	105	119	132	145
	21.00	30	45	60	74	89	104	119	134	149	164
	23.25	33	50	66	83	100	116	133	150	166	183
	25.50	37	55	73	92	110	128	147	165	183	202
	27.75	40	60	80	100	120	140	160	180	201	221
	30.00	44	65	87	109	131	152	174	196	218	239
	32.25	47	70	94	117	141	164	188	211	235	258
	34.50	50	76	101	126	151	176	202	227	252	277
	36.75	54	81	108	135	162	188	215	242	269	296
	39.00	57	86	115	143	172	201	229	258	286	315
	41.25	61	91	121	152	182	213	243	273	304	334
43.50	64	96	128	160	193	225	257	289	321	353	
45.75	68	101	135	169	203	237	270	304	338	372	

CAPACITIES IN BTU/Hr, DIMENSIONS IN INCHES

		VERTICAL PLATE WIDTH*									
		9.5	13.5	17.5	21.5	25.5	29.5	33.5	37.5	41.5	45.5
VERTICAL PLATE HEIGHT*	6.00	9	14	18	23	28	32	37	41	46	50
	8.25	13	19	25	32	38	44	50	57	63	69
	10.50	16	24	32	40	48	56	64	72	80	88
	12.75	19	29	39	49	58	68	78	88	97	107
	15.00	23	34	46	57	69	80	92	103	115	126
	17.25	26	40	53	66	79	92	105	119	132	145
	19.50	30	45	60	74	89	104	119	134	149	164
	21.75	33	50	66	83	100	116	133	150	166	183
	24.00	37	55	73	92	110	128	147	165	183	202
	26.25	40	60	80	100	120	140	160	180	201	221
	28.50	44	65	87	109	131	152	174	196	218	239
	30.75	47	70	94	117	141	164	188	211	235	258
	33.00	50	76	101	126	151	176	202	227	252	277
	35.25	54	81	108	135	162	188	215	242	269	296
	37.50	57	86	115	143	172	201	229	258	286	315
	39.75	61	91	121	152	182	213	243	273	304	334
42.00	64	96	128	160	193	225	257	289	321	353	
44.25	68	101	135	169	203	237	270	304	338	372	

When choosing the proper plate sizes, primary consideration should be given to calculated BTU loads as well as box design and usage. Any special requirements must be determined prior to selection and installation.

Evaporator plates may be used for freezer or refrigerator box applications. Plates must be specified for horizontal or vertical operation and must be oriented correctly when mounting. Vertical plates must be mounted with the refrigerant connections going up or down. However, in either case, the refrigerant must feed into the tube on the right. Horizontal plates must be mounted with the refrigerant connections going left or right. However, in either case, the refrigerant must feed into the bottom tube. Either may be used as a shelf across the interior surface. Each plate has mounting flanges with 1/4" diameter holes for securing the plates.

Plates must be mounted with stand-offs to expose the back surface area of the plate to provide proper performance. A minimum of 5/8" clearance between the box and the back of the plate is recommended.

Expansion valves must be located and fastened properly. Do not install expansion valves with the diaphragm on the bottom. Recommended location of the valve is in the box with the plate(s). The expansion valve sensing bulbs are to be properly located and secured on the outlet (suction line) of the last plate(s) in series. Recommended location is on a horizontal portion of tubing on the top (between ten and two o'clock). If either the expansion valve or its sensing bulb must be located outside of the box, each part must be properly insulated to protect against condensation, as well as to allow accurate temperature sensing of the bulb.

### Information needed when ordering dry flat evaporator plates:

- 1) Measure internal dimensions of refrigerator/ freezer box.
- 2) Calculate internal volume of box ((see example below).
- 3) Measure thickness of insulation around box.
- 4) Use appropriate chart below to get BTU/Hr gain.
- 5) See charts on front of this sheet to determine which plate(s) will fit your application.
- 6) Type of plate needed: \_\_\_\_\_ horizontal \_\_\_\_\_ vertical
- 7) List dimensions of plate(s), (width x height) \_\_\_\_\_" x \_\_\_\_\_".
- 8) Will plates fit through the opening of the box: yes/ no.
- 9) Length of refrigerant connections (8" is standard) \_\_\_\_\_".
- 10) Location of connections on horizontal plate, top/center/bottom (center is standard) \_\_\_\_\_.  
 Location of connections on vertical plate, left/center/right (center is standard) \_\_\_\_\_.

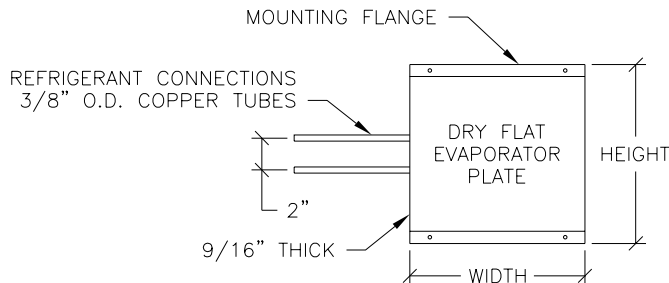

HORIZONTAL PLATE SHOWN  
SEE FRONT OF THIS SHEET  
FOR VERTICAL PLATE CONFIGURATION

45°F REFRIGERATOR BTU GAIN PER HOUR				
CUBIC FEET*	INSULATION**			
	2"	3"	4"	6"
1	30	20	15	10
2	47	31	24	16
3	62	41	31	21
4	75	50	37	25
5	87	58	43	29
6	98	65	49	33
8	119	79	59	40
10	138	92	69	46
12	156	104	78	52
14	173	115	86	58
16	189	126	94	63
18	204	136	102	68
20	219	146	110	73

10°F FREEZER BTU GAIN PER HOUR				
CUBIC FEET*	INSULATION**			
	2"	3"	4"	6"
1	46	31	23	15
2	73	49	36	24
3	96	64	48	32
4	116	77	58	39
5	134	90	67	45
6	152	101	76	51
8	184	123	92	61
10	213	142	107	71
12	241	161	120	80
14	267	178	133	89
16	292	194	146	97
18	316	210	158	105
20	339	226	169	113

0°F FREEZER BTU GAIN PER HOUR				
CUBIC FEET*	INSULATION**			
	2"	3"	4"	6"
1	51	34	26	17
2	82	54	41	27
3	107	71	53	36
4	129	86	65	43
5	150	100	75	50
6	170	113	85	57
8	205	137	103	68
10	238	159	119	79
12	269	179	135	90
14	298	199	149	99
16	326	217	163	109
18	353	235	176	118
20	378	252	189	126

-10°F FREEZER BTU GAIN PER HOUR				
CUBIC FEET*	INSULATION**			
	2"	3"	4"	6"
1	57	38	28	19
2	90	60	45	30
3	118	79	59	39
4	143	95	72	48
5	166	111	83	55
6	187	125	94	62
8	227	151	114	76
10	263	176	132	88
12	297	198	149	99
14	330	220	165	110
16	360	240	180	120
18	390	261	195	130
20	418	279	209	139

(48) Example Circled: A 10° freezer box with inside dimensions of 24" height, 12" depth and 18" width has an internal volume of 5,184 in<sup>3</sup> (24.00" x 12.00" x 18.00"). Divide the 5,184 in<sup>3</sup> by 1,728 (one cubic foot) to get three cubic feet. With 4" of insulation, a 48 BTU/hr gain is found on the chart. Referring to the capacities charts on the front of this sheet, two 12.00" x 12.00" horizontal (48 BTU/hr), two 13.50" x 10.50" vertical (48 BTU/hr), one 12.00" x 23.25" horizontal (50 BTU/hr) or one 13.50" x 21.75" vertical (50 BTU/hr) plate(s) may be used.

\* To convert cubic meters to cubic feet, multiply by 35.31

\*\* Two pound density poly-foam insulation with an R value of 5.5 and ambient temperature of 95° F.

### DOMETIC MARINE DIVISION

2000 N. Andrews Ave. Ext. I Pompano Beach, FL 33069 USA | 954-973-2477 | Fax 954-979-4414  
www.DometicUSA.com | MarineSales@DometicUSA.com

### 24/7 Tech Support for United States & Canada:

8:00 AM to 5:00 PM Eastern Time: 800-542-2477  
After hours and weekends: 888-440-4494

### International Sales & Service:

Europe & the Middle East: Call +44(0)870-330-6101  
For all other areas visit our website to find your nearest distributor.



Environmentally Responsible

Dealer:

# Holdover Plates



### True Eutectic Solution

- Specially formulated mixture of water, salts and inhibitors.
- Provides stable box temperatures throughout holdover period.
- Injected into plates under a vacuum (30 microns).
- Four temperature ranges available: 0°F (-18°C), -9°F (-23°C), and -18°F (-28°C) for freezer applications and 26°F (-3°C) for refrigerator applications.

### Unique Stainless Steel Construction

- Hand polished #304 stainless steel (.062) for clean, aesthetic appearance.
- Easy mount flange system on short side of all plates.
- Internally gusseted steel tubing improves thermal transfer and is high pressure tested to 550 psi.
- Hand welded seams by certified TIG welders.
- Wide variety of sizes and ranges to accommodate various box designs.

### Dual Circuit Design

- Permits paralleled operation for engine drive and AC or DC voltage condensing units for redundancy.
- Retrofit crossover assembly for easy conversion to single unit.
- Rapid "pull down" of plate temperature when run with a double pass on one condensing unit.
- Dual set of thermostat sensing wells for accurate temperature control.

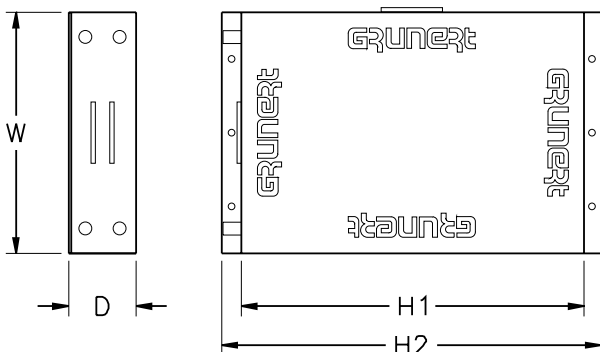

Plate Selection <sup>1</sup>	12 x 10	16 x 10	20 x 8	20 x 10	16 x 14	24 x 10	24 x 13
<b>Capacity (BTU/hr)</b>							
Refrigerator (26°F/-3°C)	1243	1708	1980	2174	2356	2653	3469
Freezer (0°F/-18°C)	1117	1536	1780	1955	2118	2385	3118
Freezer (-9°F/-23°C)	1023	1438	1480	1851	2025	2265	2984
Freezer (-18°F/-28°C)	1058	1486	1531	1914	2095	2342	3086
<b>Dimensions (in/mm)<sup>2</sup></b>							
H1 (Height)	10.0/254	14.0/356	18.0/457	18.0/457	14.0/356	22.0/559	22.0/559
H2 (Height) <sup>3</sup>	11.5/292	15.5/394	19.5/495	19.5/495	15.5/394	23.5/597	23.5/597
W (Width)	10.0/254	10.0/254	8.0/203	10.0/254	14.0/356	10.0/254	13.0/330
D (Depth)	26°F and 0°F plates = 3.0/7.6 -9°F and -18°F plates = 3.38/8.6						
Weight (lb/kg)	19.0/8.6	26.0/11.8	28.0/12.7	33.0/15.0	34.0/15.5	35.0/15.9	54.0/24.5
Refrigerant Connections <sup>4</sup>	1/2" O.D. x 3/4" L - S.S. Stubs						

Notes:

<sup>1</sup> Plates can be mounted in either horizontal or vertical configurations, with connections either at right, left, up or down. Refrigerant line connections are always located on short dimension of plate.  
<sup>2</sup> Custom plate sizes on request.  
<sup>3</sup> Dimension includes two 3/4" flanges with 1/4" diameter mounting holes.  
<sup>4</sup> All plates can be prefabricated to customer's requirements, including copper stubs, flare connections and fittings, crossover assemblies and Swagelock™ fittings.

When choosing the proper plate sizes, primary consideration should be given to calculated BTU loads as well as box design and usage. Any special requirements must be determined prior to selection and installation.

Holdover plates are available with 26°F (-3°C) eutectic solution for refrigerator box applications, and 0°F (-18°C), -9°F (-23°C) and -18°F (-28°C) solutions for freezer box applications. The freezer plates are identified with 1, 2, or 3 (for the 0, -9 and -18°F plates respectively) V-notches located on the mounting flange at the same end as the refrigerant line connections. The 26°F plates have no notch in the flange. All plates have a serial code and plate temperature inscribed on the back of the mounting flange on the opposite end.

The Grunert line of holdover plates is designed to be installed in any position on a box's interior surface, or as a shelf across the interior space. Each plate has mounting flanges across both short ends (smaller dimension) with 1/4" diameter mounting holes. Secure the plate(s) with the proper fasteners (lag screws, thru-wall connectors, etc.) to support the weight and torsion load from the vessel's movement.

Plates must be mounted with stand-offs to expose the back surface area of the plate to provide proper performance. A minimum of 5/8" (1.6cm) clearance between the box and the back of the plate is recommended.

Expansion valves must be located and fastened properly. Do not install expansion valves with the diaphragm on the bottom. Recommended location of the valve is in the box(es) with the plate. The expansion valve sensing bulbs are to be properly located and secured on the outlet (suction line) of the last plate in series. Recommended location is on a horizontal portion of tubing on the top (between ten and twelve o'clock). If either the expansion valve or its sensing bulb must be located outside of the box, each part must be properly insulated to protect against condensation, as well as to allow accurate temperature sensing of the bulb.

Thermostat sensing bulbs are to be inserted into the sensing wells located on the holdover plate. Two sets of wells are located on two sides of each plate. Once a plate has been positioned in a box, the well(s) that are located on the side (vertical surface) should be used for the most accurate sensing of plate temperature.

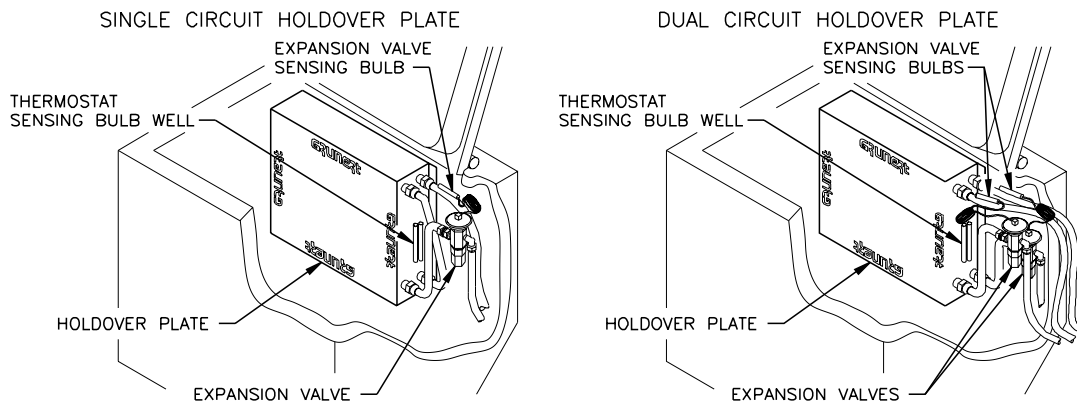

26°F REFRIGERATOR PLATE				
BTU LEAK IN 24 HOURS	VOLUME IN CUBIC FEET*			
	6"	4"	3"	2"
5200				14
5000				13
4800		20		
4600		18	12	
4400		16	11	
4200		16	10	
4000			14	
3800		20	12	8
3600		18	12	8
3400		16	10	7
3200	20	14	9	6
3000	18	13	8	6
2800	11	7	5	
2600	14	10	6	4
2400	12	8	5	
2200	10	8	4	3
2000	8	6	4	3
1800	6	5	3	2
1600	4	4	2	
1400	3	3		
1200	2	2	1	1
1000				

0°F FREEZER PLATE				
BTU LEAK IN 24 HOURS	VOLUME IN CUBIC FEET*			
	6"	4"	3"	2"
5200	16	11	8	5
5000		10	7	
4800	14		7	
4600		8	6	4
4400	12		6	4
4200		10	5	3
4000	10		5	3
3800		6	4	
3600	8		4	
3400	6			
3200		4	3	2
3000	4		3	2
2800	4	3		
2600	3	3	2	
2400		2		1
2200	2	2		1
2000				
1800			1	
1600	1	1		
1400				
1200				
1000				

-9°F FREEZER PLATE				
BTU LEAK IN 24 HOURS	VOLUME IN CUBIC FEET*			
	6"	4"	6"	4"
5200		10		
5000	14			
4800				
4600	12	8		
4400	10			
4200		8		
4000	8	6		
3800				
3600	6	4		
3400		4		
3200	4	3		
3000		3	20	
2800	4	3		20
2600			18	7000
2400		2		6800
2200	2			6600
2000			16	6400
1800	1	1		6200
1600			20	6000
1400				5800
1200			18	5600
1000			16	5400

-18°F FREEZER PLATE					
BTU LEAK IN 24 HOURS	VOLUME IN CUBIC FEET*				BTU LEAK IN 24 HOURS
	6"	4"	6"	4"	
5200	12	8			9600
5000					9400
4800	10				9200
4600					9000
4400	8	6			8800
4200					8600
4000					8400
3800	6			20	8200
3600		4			8000
3400					7800
3200	4	3		18	7600
3000					7400
2800	3			16	7200
2600		2			7000
2400	2				6800
2200				20	6600
2000		1			6400
1800	1	1		18	6200
1600				16	6000
1400				10	5800
1200				14	5600
1000					5400

③ EXAMPLE CIRCLED: A 0° freezer box with inside dimensions of 24" height, 12" depth and 18" width has an internal volume of 5184 cubic inches (24x12x18). Divide the 5184 cubic inches by 1728 (one cubic foot) to get three cubic feet. With 4" of insulation, a 2700BTU leak is found from the chart. Referring to the 0° Freezer Capacity (BTUs) row on the front of this sheet, two 16x10 plates (3072BTUs) or one 24x13 plate (3118BTUs) may be used.

\* TO CONVERT CUBIC METERS TO CUBIC FEET, MULTIPLY BY 35.31

\*\* CHART IS DESIGNED USING POLY FOAM WITH A TWO POUND DENSITY RATING

### DOMETIC MARINE DIVISION

2000 N. Andrews Ave. Ext. I Pompano Beach, FL 33069 USA | 954-973-2477 | Fax 954-979-4414  
www.DomesticUSA.com | MarineSales@DomesticUSA.com

### 24/7 Tech Support for United States & Canada:

8:00 AM to 5:00 PM Eastern Time: 800-542-2477

After hours and weekends: 888-440-4494

### International Sales & Service:

Europe & the Middle East: Call +44(0)870-330-6101

For all other areas visit our website to find your nearest distributor.



Environmentally Responsible

Dealer:

# Eskimo Ice Fishbox Ice Systems

## For Serious Tournament Anglers



- Keep your catch fresh all day.

EI600D-115 Self-Contained Model



**Crushed ice—preferred by fishermen—cools more quickly and packs better.** A Dometic Eskimo Ice system produces up to 600 pounds (272 kg) of crushed ice per day to keep even the largest catches fresh. Ice is generated within minutes after starting the unit, and makes up to 25 pounds (11.3 kg) of ice per hour under normal operating conditions.

The easy-to-install Eskimo Ice system is designed to be mounted below deck or in an engine room where it is protected from salt spray. The ice it produces can be pumped through hose lengths up to 30 feet (9.1 meters) to nearly any desired location onboard, such as a fish box or cooler.



All self-contained and remote Eskimo Ice systems feature the Smart Logic Digital Display. A full menu of sensors and status lights monitor gas pressure, auger motor, compressor, water level, ice level, and ice clogs, and will shut off the system if problems are detected. The system automatically resets and restarts for certain key functions that can be triggered by extreme boat motion.

Available in either 60Hz or 50Hz versions. Digital-control retrofit kits are available.

### Key Benefits

- Available in 60Hz or 50Hz.
- Self-contained and remote models available with Smart Logic digital control.
- Up to two remotely mounted digital displays/user interface panels.
- Photo-electric ice-level sensor.
- Start-time delay.
- Fresh water filter included.
- Pre-charged system.
- Sensors monitor all system functions.
- Manual reset to restart system from lock-out.
- Improved fresh-water float switch.
- Redesigned refrigerant meter for improved performance in cold water.
- Optional side and top covers for protection and improved appearance.

# Technical Specifications for Eskimo Ice 600 Series

Model	Volts/Freq/Ph	Running Amps	LRA	Capacity <sup>(1)</sup>	Water Consumption	Dimensions (in/mm)			Net Weight (lb/kg)
						Width	Depth	Height	
<b>Remote Systems</b>									
EIR600-115 Condensing Unit	115/60/1	14.0	66.3	N/A	N/A	12.88/327	12.88/327	15.00/381	67/30.5
EIR600-115 Auger Unit	115/60/1	2.0	N/A	600 lb/day	60 gal/day	14.25/362	16.38/416.1	20.88/530.4	83/37.7
EIR600-230 Condensing Unit	230/60/1	7.0	33.5	N/A	N/A	12.88/327	12.88/327	15.00/381	67/30.5
EIR600-230 Auger Unit	230/60/1	1.0	N/A	600 lb/day	60 gal/day	14.25/362	16.38/416.1	20.88/530.4	83/37.7
EIR600-220 Condensing Unit	220/50/1	6.5	40.0	N/A	N/A	12.88/327	12.88/327	15.00/381	67/30.5
EIR600-220 Auger Unit	220/50/1	1.0	N/A	500 lb/day <sup>(2)</sup>	60 gal/day	14.25/362	16.38/416.1	20.88/530.4	83/37.7
Remote Electrical Box	N/A	N/A	N/A	N/A	N/A	9.25/234	5.38/136	6.38/162	4.00/1.81
<b>Self-Contained Systems</b>									
EI600D-115	115/60/1	16.0	66.3	600 lb/day	60 gal/day	17.50/445	23.50/597	22.00/559	135.00/61.4
EI600D-230	230/60/1	7.5	33.5	600 lb/day	60 gal/day	17.50/445	23.50/597	22.00/559	135.00/61.4
EI600D-220	220/50/1	8.0	40.0	500 lb/day <sup>(2)</sup>	60 gal/day	17.50/445	23.50/597	22.00/559	135.00/61.4

Notes:  
<sup>(1)</sup> Capacity ratings depend upon conditions.  
<sup>(2)</sup> Rated at 500 (227 kg) lbs per day because of 50Hz derate.

- The Eskimo Ice basic kit includes:**
- Ice Machine with condensate pan.
  - 15' (4.5m) of ice-delivery hose and insulation.
  - Electronic ice-level control unit.
  - Complete installation instructions.
  - Fresh water filter

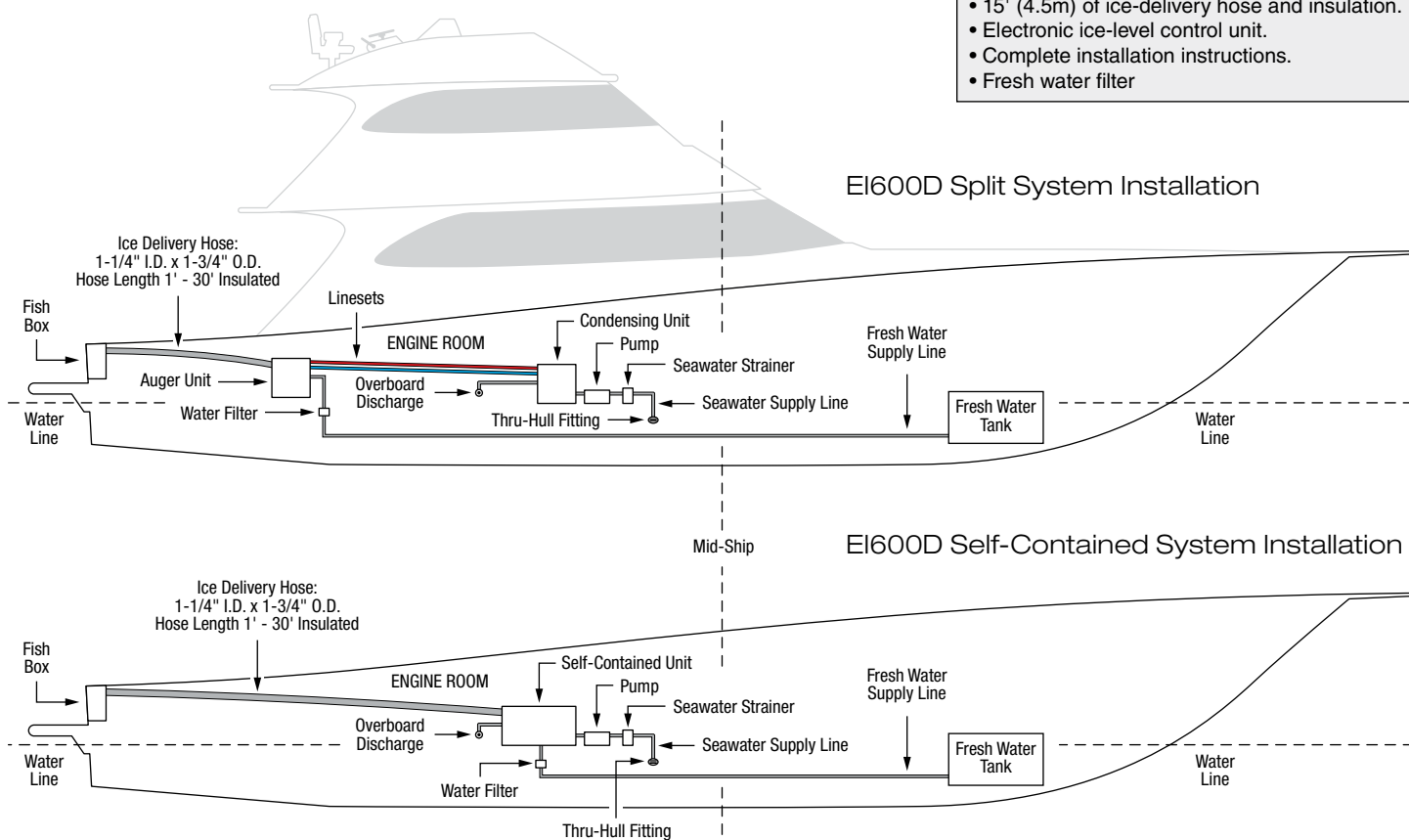

**DOMETIC MARINE DIVISION**  
 2000 N. Andrews Ave. Ext. I Pompano Beach, FL 33069 USA | 954-973-2477 | Fax 954-979-4414  
 www.DometicUSA.com | MarineSales@DometicUSA.com

**24/7 Tech Support for United States & Canada:**  
 8:00 AM to 5:00 PM Eastern Time: 800-542-2477  
 After hours and weekends: 888-440-4494

**International Sales & Service:**  
 Europe & the Middle East: Call +44(0)870-330-6101  
 For all other areas visit our website to find your nearest distributor.



Dealer:



# Ice Cube Fishbox Ice System

Produces Up to 250 Lbs. of Ice a Day

50Hz Models  
Now Available!



■ Keep your catch fresh all day.

EI250D-115 shown



## The Ice Cube - A Smaller Crushed-Ice System

Dometic Eskimo Ice is available in a smaller version—the Ice Cube—for boats with less space or less demand for daily ice output. Cube-shaped, with a footprint of only 16" x 16" (413mm x 413mm), the Ice Cube makes up to 250 lbs. (113 kg) of crushed ice per day. Ice is generated within minutes after starting the unit, and makes more than 10 lbs. (4.5 kg) of ice per hour under optimal operating conditions.

The Ice Cube is a self-contained unit and easy to install. The ice it produces can be pumped through insulated hose lengths up to 15' (4.5m), to nearly any desired location onboard, such as a fish box or cooler.



Operation of the Ice Cube is easy with its Smart Logic Digital Displays. A full menu of sensors and status lights monitor gas pressure, auger motor, compressor, water level, ice level, and ice clogs, and will shut off the system if problems are detected. But the system automatically resets and restarts for certain key faults.

## Key Benefits

- Small footprint—16" x 16" (413mm x 413mm).
- Available in 50Hz and 60Hz models.
- Up to two remotely mounted digital displays/user interface panels.
- Photo-electric ice-level sensor.
- Start-time delay.
- Water filter included.
- Pre-charged system.
- Sensors monitor all system functions.
- Manual reset to restart system after lock-out.
- Improved fresh-water float switch.
- Ventilated cover panels are removable for servicing from virtually any side of the unit.

## Technical Specifications for Ice Cube

Model	EI250D-115	EI250D-220V/50
Capacity per day (lbs/kg)	250/113 <sup>(1)</sup>	
Capacity per hour (lbs/kg)	>10.42/>4.73 <sup>(1)</sup>	
Voltage	115	220
Frequency	60Hz	50Hz
Full Load Amps (FLA) Cool	9.68	4.50
Locked Rotor Amps (LRA)	40.00	14.80
Refrigerant	R-134A	
Water consumption, gallons per day	30 @ 250 lbs	
Water consumption, liters per day	113.56 @ 113.4	
<b>Dimensions</b>		
Height (in/mm)	16.25/413	
Width (in/mm)	16.25/413	
Length (in/mm)	16.25/413	
<b>Connections</b>		
Sea water (in/type)	5/8"/hose barb	
Fresh water (in/type)	1/4"/SAE	
<b>Weight</b>		
Net weight (lbs/kg)	82.0/37.2	
Shipping weight (lbs/kg)	97.0/43.9	

Notes:

<sup>(1)</sup> Under optimal conditions.

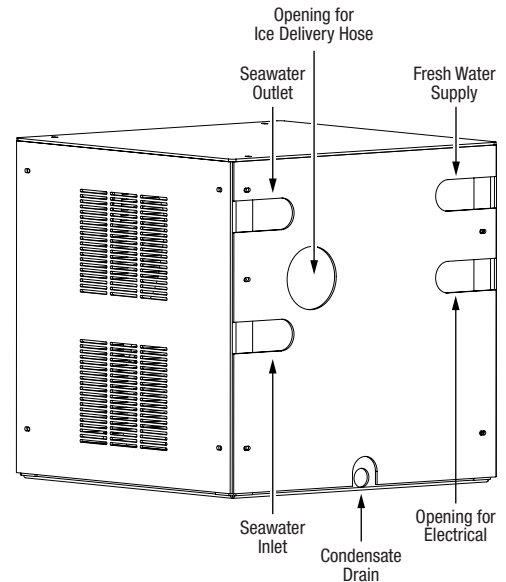

**The Ice Cube basic kit includes:**

- Ice Cube ice-making system.
- (1) Smart Logic digital display.
- Water filter.
- 15' (4.5m) of ice-delivery hose and insulation.

## Recommended Ice Cube System Installation

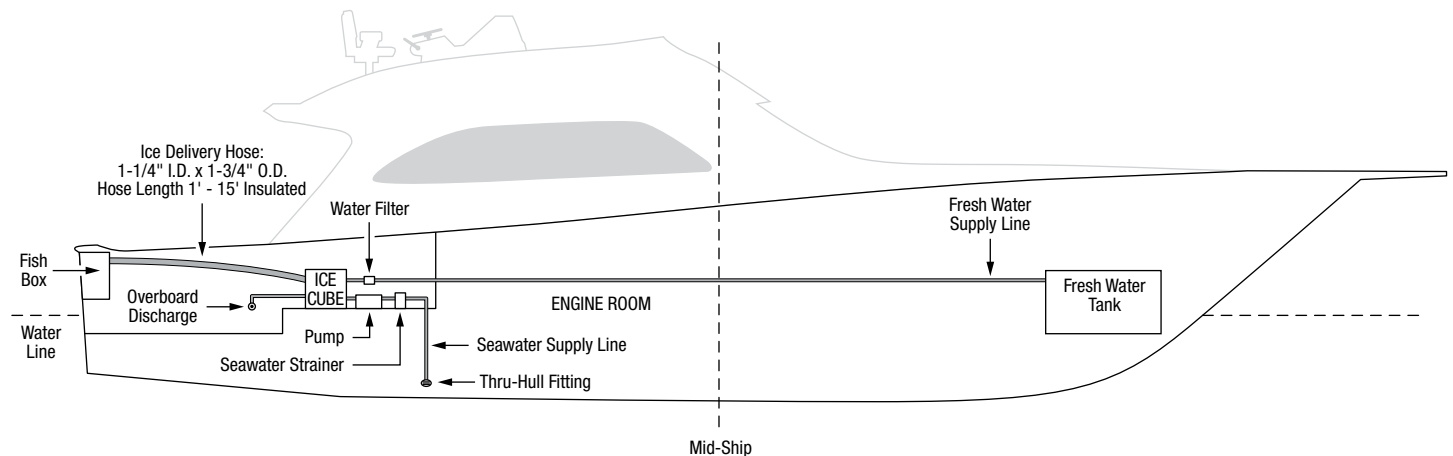

**DOMETIC MARINE DIVISION**

2000 N. Andrews Ave. Ext. I Pompano Beach, FL 33069 USA | 954-973-2477 | Fax 954-979-4414  
 www.DometicUSA.com | MarineSales@DometicUSA.com

**24/7 Tech Support for United States & Canada:**

8:00 AM to 5:00 PM Eastern Time: 800-542-2477  
 After hours and weekends: 888-440-4494

**International Sales & Service:**

Europe & the Middle East: Call +44(0)870-330-6101  
 For all other areas visit our website to find your nearest distributor.



Environmentally Responsible

Dealer:



## Certified Worldwide Sales & Service Network



Represents sales and service coverage range



**DOMETIC MARINE DIVISION**

2000 N. Andrews Ave. Ext. I Pompano Beach, FL 33069 USA | 954-973-2477 | Fax 954-979-4414  
[www.DometicUSA.com](http://www.DometicUSA.com) | [MarineSales@DometicUSA.com](mailto:MarineSales@DometicUSA.com)

**24/7 Tech Support for United States & Canada:**

8:00 AM to 5:00 PM Eastern Time: 800-542-2477  
 After hours and weekends: 888-440-4494

**International Sales & Service:**

Europe & the Middle East: Call +44(0)870-330-6101  
 For all other areas visit our website to find your nearest distributor.

Dealer:

